



## Pioneer 321 MSR



GB

Instruction manual







---

1	<b>INTRODUCTION</b> .....	4
2	<b>FRONT PANEL</b> .....	4
3	<b>REAR PANEL</b> .....	5
4	<b>INSTALLATION</b> .....	6
4.1	UNIT ASSEMBLY .....	6
4.2	CONNECTIONS TO THE ELECTRICAL MAINS NETWORK	6
5	<b>USER INTERFACE</b> .....	7
6	<b>TECHNICAL DATA</b> .....	8
7	<b>SPARE PARTS</b> .....	9
7.1	PIONEER 321 MSR .....	9
8	<b>ELECTRICAL DIAGRAM</b> .....	11
8.1	PIONEER 321 MSR→WF-107 CABLE .....	13

## 1 INTRODUCTION

## 2 FRONT PANEL

 **IMPORTANT!**

This handbook must be consigned to the user prior to installation and commissioning of the unit.





Read the "General prescriptions for use" handbook supplied separately from this handbook before installing and commissioning the unit.

The meaning of the symbols in this manual and the associated precautionary information are given in the "General prescriptions for use".

If the "General prescriptions for use" are not present, it is mandatory to request a replacement copy from the manufacturer or from your dealer.

Retain these documents for future consultation.

### KEY

-  This symbol identifies an action that occurs automatically as a result of a previous action.
-  This symbol identifies additional information or a reference to a different section of the manual containing the associated information.
-  This symbol identifies a reference to a chapter of the manual.
-  This symbol accompanies important information concerning the execution of the relevant operations.

Pioneer 321 MSR is a power source for welding.  
When combined with a wire feeder it can be used for MIG/MAG welding.

Accessories that can be connected to the unit:

- wire feeding unit.
- liquid cooler for torches.

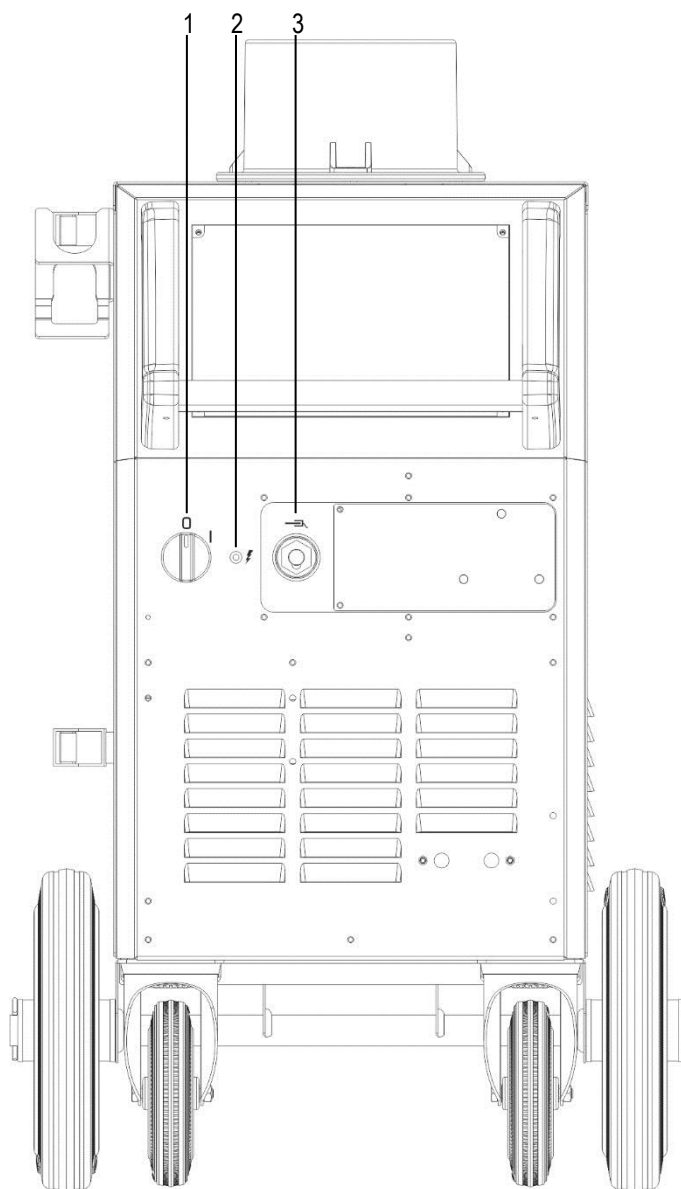

- 1: Welding power source ON/OFF switch.
- 2: Mains protection ON LED.  
This LED illuminates if an incorrect operating condition occurs:
  - absence of a phase in the power supply line.
- 3: Earth welding socket.

### 3 REAR PANEL

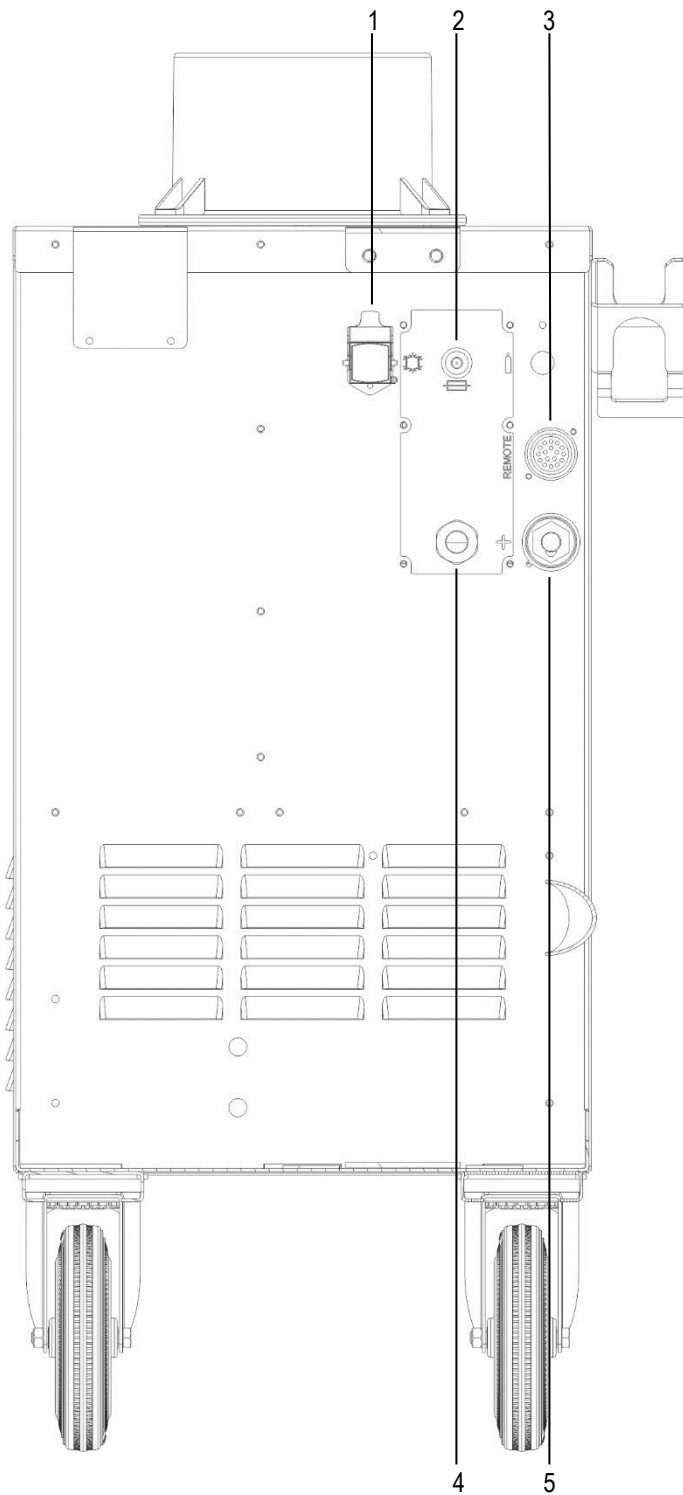

1: Cooler power feeding connector.

Voltage	230 V~
Current Output	0.8 A
IP protection rating	IP20 (cap open) IP66 (cap closed)

**WARNING!**  
**High voltage!**

If the socket is not connected to any devices always close the cap: presence of hazardous voltage levels!

2: Power supply transformer fuse.

Type	Delayed acting (T)
Amperage	2 A
Voltage	500 V

3: Connector of the bundle of cables for connecting the power source to the remote control device.

4: Power cable.

Total length (including internal part)	4,5 m
Number and cross section of wires	4 x 4,0 mm <sup>2</sup>
Power plug type	Not supplied

5: Socket for connecting the power cable between the power source and the remote control device.

## 4 INSTALLATION

**WARNING!**  
**Lifting and positioning**

Read the warnings highlighted by the following symbols in the "General prescriptions for use".



### 4.1 UNIT ASSEMBLY

1. Fit the front swivel wheels with the supplied screws.
2. Screw the fixed rear wheels to the studs in the base of the unit and secure them with the supplied nuts.

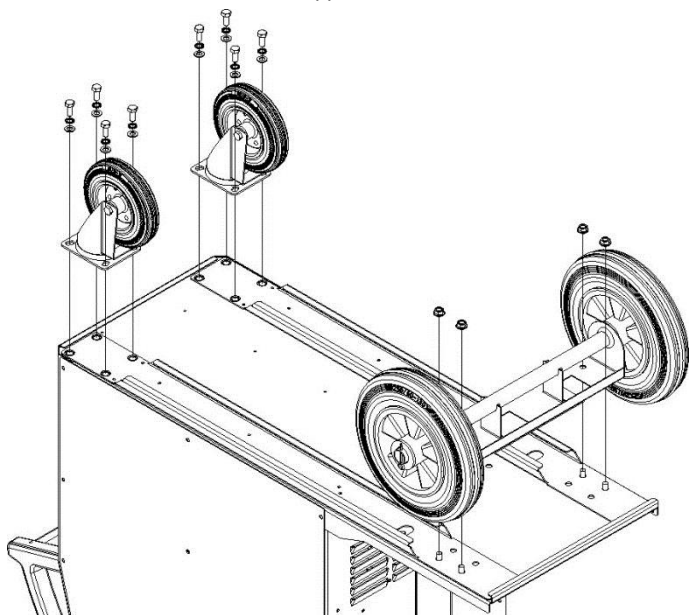

3. Mount the cooler in the relevant location.
4. Screw the cooler fixing bracket to the welding power source chassis using the supplied screws.
5. Screw the base of the cooler to the unit base using the supplied screws.
6. Connect the plug of the cooler power cable to the cooler power socket on the rear panel of the welding power source.

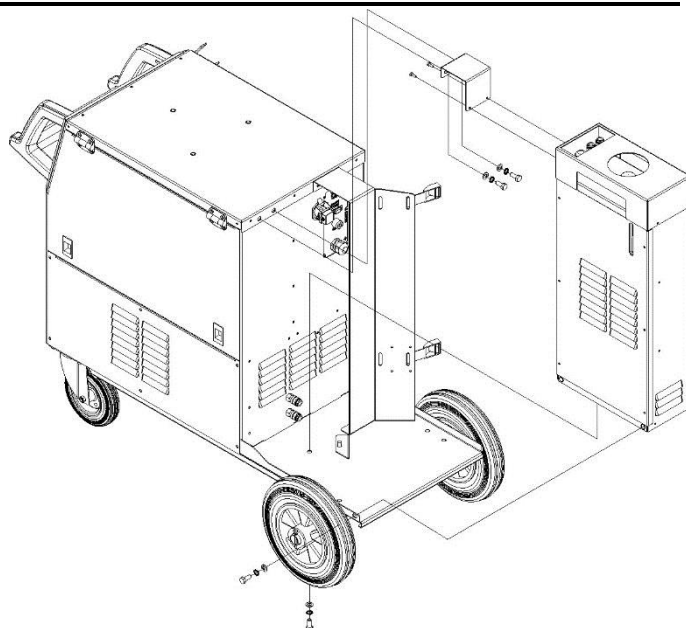

### 4.2 CONNECTIONS TO THE ELECTRICAL MAINS NETWORK

The characteristics of the mains power supply to which the equipment shall be connected are given in the section entitled "technical data" on page 8.

The machine can be connected to motogenerators provided their voltage is stabilised.

Connect/disconnect the various devices with the machine switched off.

## 5 USER INTERFACE

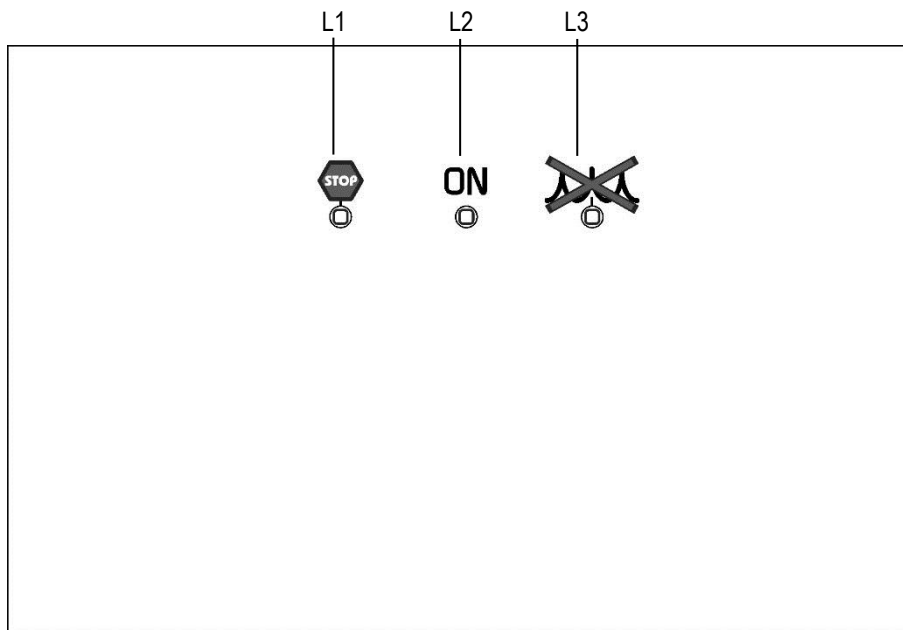

CODE	SYMBOL	DESCRIPTION
L1		This LED illuminates to show an anomaly in the operating conditions. For information on alarm management, please refer to the relevant section in the manual of the wire feeder.
L2	<b>ON</b>	This LED illuminates to confirm the presence of power on the output sockets. Illuminates to show that the cooling unit pressure switch does not detect any pressure. - Check that the connection to the cooler is correct.
L3		- Check that the O/I switch is set to I and that it illuminates when the pump is running. - Check that the cooler is filled with coolant. - Check that the cooling circuit is liquid tight, notably the torch hoses and the internal connections of the cooler.



## 6 TECHNICAL DATA

Model	Pioneer 321 MSR		
Construction standards	EN 60974-1 EN 60974-10 Class A		
Supply voltage	3 x 400 V~±15 % / 50-60 Hz		
Mains protection	16 A Delayed		
Dimensions ( L x D x H )	1110 x 530 x 750 mm		
Weight	58 kg		
Insulation class	H		
Protection rating	IP23		
Cooling	AF		
Supply voltage	3 x 400 V~±15 % / 50-60 Hz		
Temperature of the environment	40°C		
Welding mode	MIG/MAG		
Static characteristic			
Work cycle	45 %	60 %	100 %
Welding current	320 A	280 A	230 A
Working voltage	30.0 V	28.0 V	25.5 V
Maximum input power	11.6 KVA	9.5 KVA	7.1 KVA
Maximum supply current	17.0 A	13.6 A	10.2 A
Maximum effective current	11.4 A	10.5 A	10.2 A
Open-circuit voltage (U <sub>0</sub> )	50 V		

Z<sub>max</sub>

This equipment complies with IEC 61000-3-12 provided that the maximum permissible system impedance is less than or equal to 83 mΩ at the interface point between the user's supply and the public system.  
It is the responsibility of the installer or user of the equipment to ensure, by consultation with the distribution network operator if necessary, that the equipment is connected only to a supply with maximum permissible system impedance less than or equal to 83 mΩ.



## 7 SPARE PARTS

### 7.1 PIONEER 321 MSR

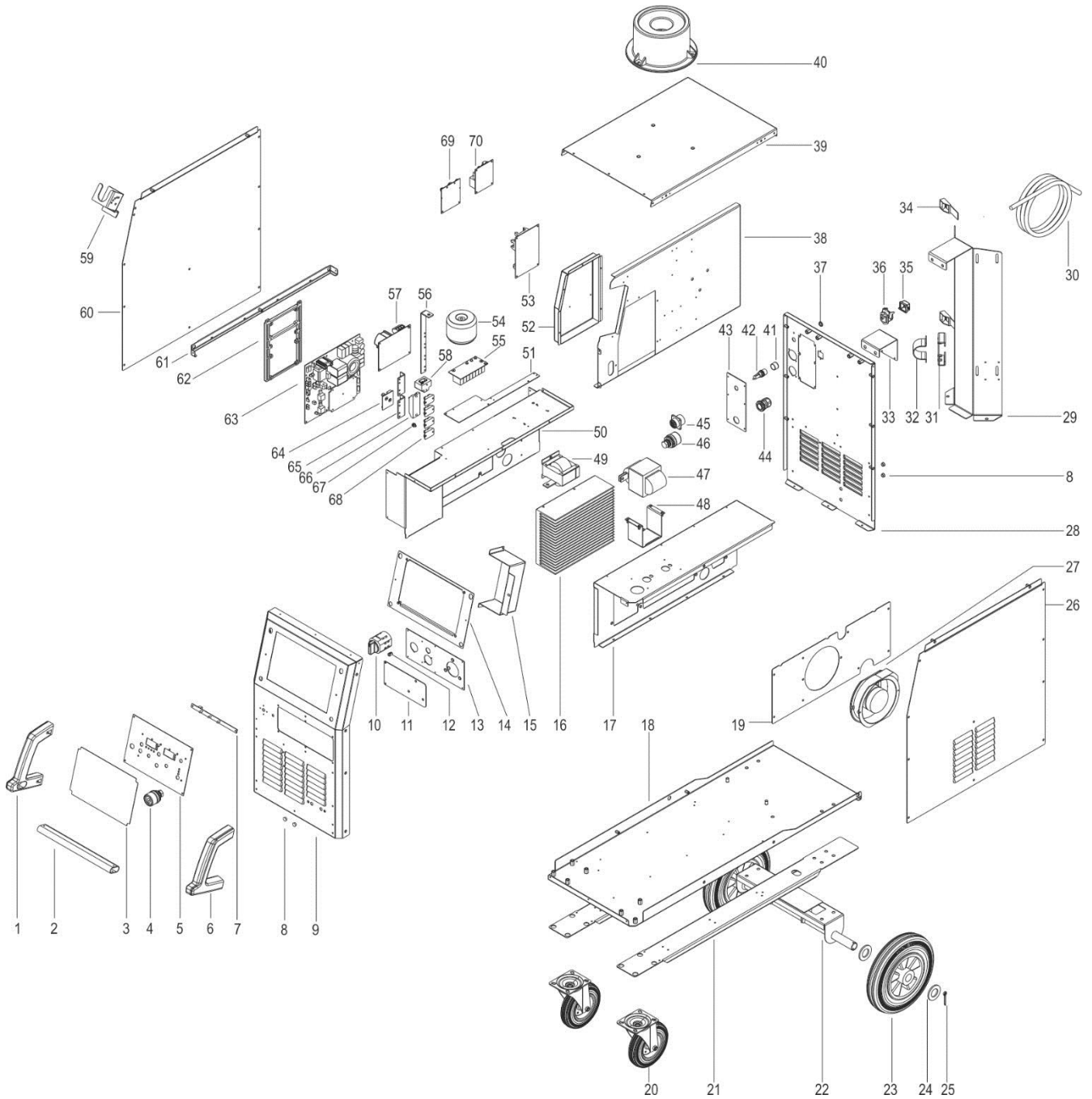



N°	CODE	DESCRIPTION
1	011.0006.0030	RIGHT HANDLE
2	011.0016.0128	FRONT HANDLE
3	013.0021.0701	FRONT PANEL LABEL
4	021.0001.0259	FIXED SOCKET 400 A
5	013.0000.8013	LOGIC BOARD PLATE
6	011.0006.0029	LEFT HANDLE
7	050.0001.0096	LED BOARD
8	016.0011.0001	CAP Ø=10
9	011.0016.0134	FRONT PLATE (1)
10	040.0001.0017	THREE-POLE SWITCH
11	011.0016.0145	FRONT PLATE (2)
12	022.0002.0190	LED WIRING
13	011.0016.0144	FRONT PLATE (3)
14	011.0016.0109	PANEL SUPPORT PLATE
15	011.0016.0151	FRONT LOGIC BOARD COVER PLATE
16	015.0001.0019	HEAT SINK
17	011.0016.0147	MOTOR SUPPORT PLATE (1)
18	011.0016.0136	LOWER COVER
19	011.0016.0153	FANS SUPPORT PLATE
20	004.0001.0013	CASTOR
21	011.0016.0138	BASE SLIDE METAL PLATE
22	011.0016.0129	WHEEL FIXING PLATE
23	004.0001.0014	FIXED WHEEL
24	016.1000.1002	WASHER M27
25	016.0002.0005	SPLIT PIN
26	011.0000.0941	RIGHT COVER PANEL
27	003.0002.0016	FAN
28	011.0016.0135	REAR PLATE (1)
29	011.0016.0139	GAS BOTTLE SUPPORT PLATE
30	045.0002.0014	NEOPRENE CABLE
31	011.0015.0204	CABLE BUNDLE SUPPORT PLATE (1)
32	011.0014.0026	CABLE BUNDLE SUPPORT PLATE (2)
33	011.0012.0058	COOLING UNIT SUPPORT PLATE
34	005.0001.0012	BELT FOR GAS BOTTLE
35	021.0013.0007	C.U. POWER CONNECTOR CAP
36	022.0002.0132	C.U. POWER SUPPLY WIRING
37	016.0011.0002	CAP Ø=13.5
38	011.0016.0148	INTERNAL PLATE
39	011.0016.0140	UPPER COVER
40	006.0002.0022	WF SUPPORT
41	016.0011.0004	FUSE HOLDER CAP
42	040.0006.1880	FUSE HOLDER
43	013.0000.7001	REAR PLATE (2)
44	045.0000.0017	CABLE CLAMP
45	022.0002.0165	REMOTE LOGIC CABLE
46	021.0001.0259	FIXED SOCKET 400 A
47	042.0003.0004	POWER TRANSFORMER
48	011.0009.0121	TRANSFORMER SUPPORT PLATE
49	044.0004.0014	OUTPUT INDUCTOR
50	011.0016.0146	TUNNEL HOUSING (1)
51	011.0016.0152	BOARDS SUPPORT
52	011.0016.0149	WIRE FEEDER COVER PLATE
53	050.0012.0094	LOGIC BOARD
54	041.0006.0007	AUXILIARY TRANSFORMER
55	050.0001.0119	PRIMARY CAPACITOR BOARD
56	045.0006.0082	DIODES-SOCKET COPPER BRACKET
57	050.0001.0147	MAINS FILTER BOARD
58	041.0004.0301	HALL EFFECT SENSOR
59	011.0015.0029	TORCH HOLDER
60	011.0000.0931	LEFT COVER PANEL
61	011.0016.0143	COVER PANEL SUPPORT PLATE
62	012.0003.0000	INTERNAL FRAMEWORKS
63	050.0002.0091	POWER BOARD
64	050.0001.0044	SNUBBER BOARD
65	045.0006.0081	DIODE-DIODE BRACKET
66	032.0001.8215	THREE PHASE BRIDGE RECTIFIER
67	040.0003.1002	THERMAL CUT-OUT 75°C
68	032.0002.2003	ISOTOP DIODE
69	050.0002.0057	POWER SUPPLY CONTROL BOARD
70	050.0001.0086	FAN AND C.U. CONTROL BOARD



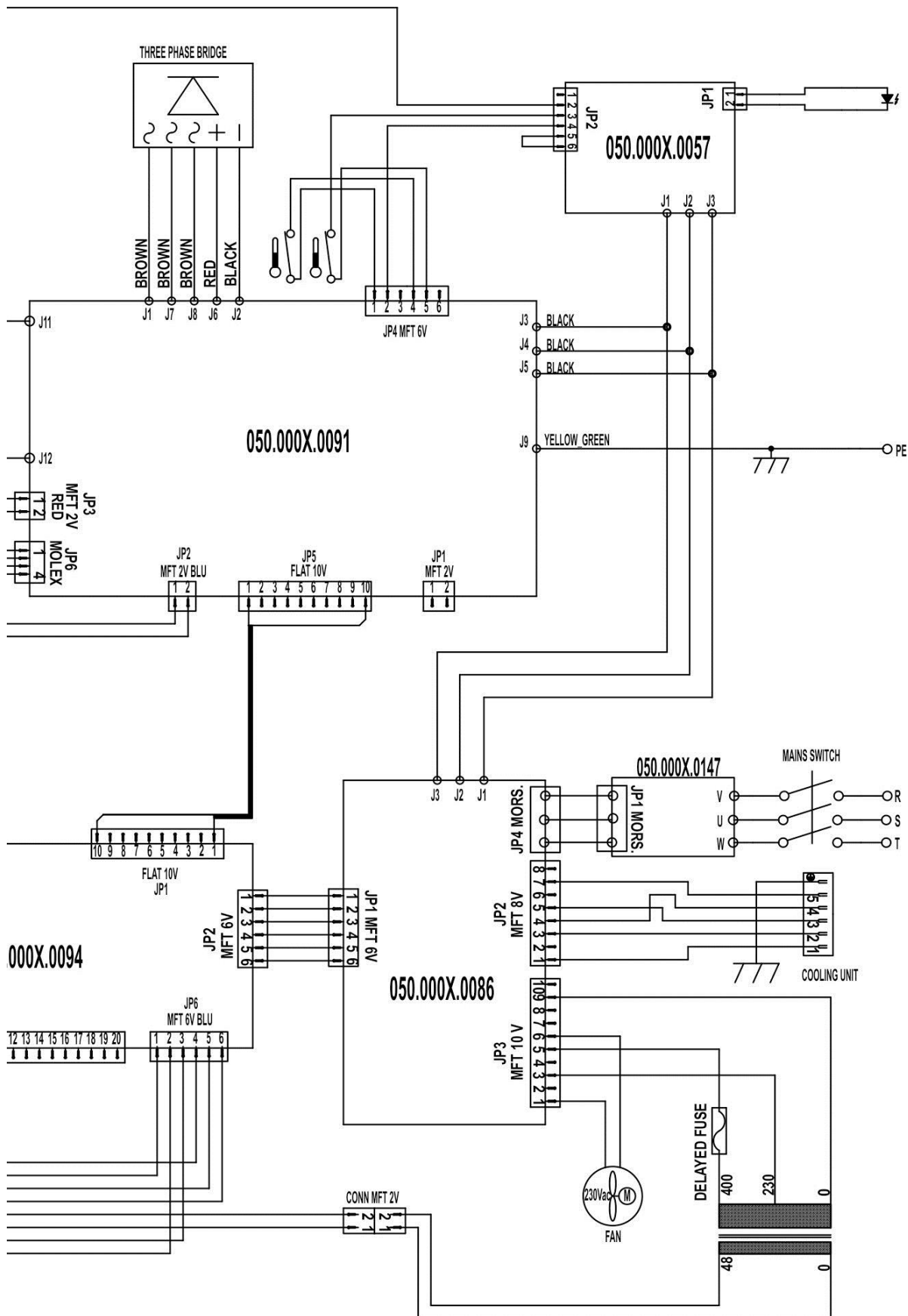

8.1 PIONEER 321 MSR → WF-107 CABLE

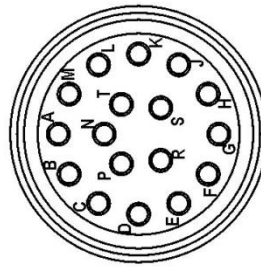
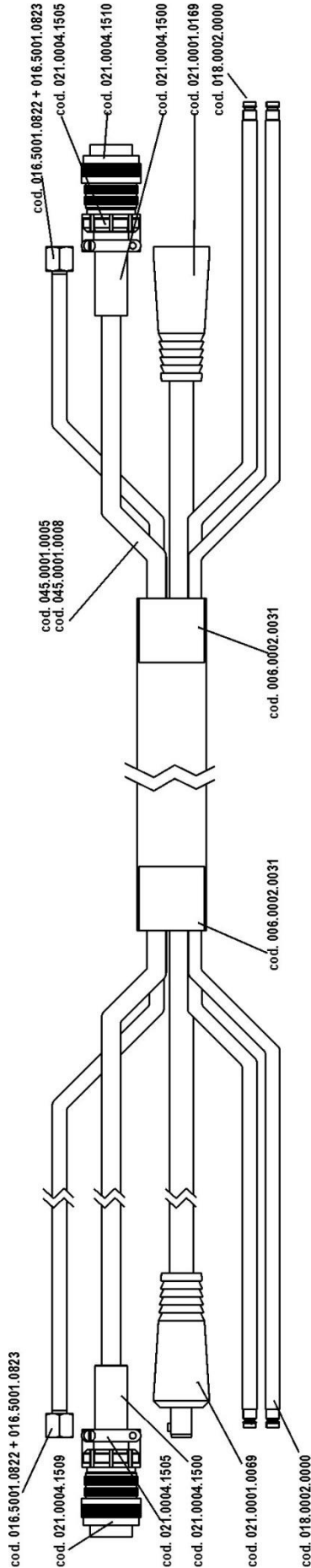

cod. 021.0004.1509

A	RED	ROSSO	A
B	BLUE	BLU	B
C	VIOLET	VIOLA	C
D	PINK	ROSA	D
E	GREY	GRIGIO	E
F	WHITE	BIANCO	F
G	BROWN	MARRONE	G
H	GREEN	VERDE	H
J	YELLOW	GIALLO	J
K	WHITE/GREEN	BIANCOVERDE	K
L	GREEN/BROWN	VERDE/MARRONE	L
M	RED/BLUE	ROSSO/BLU	M
N	PINK/GREY	ROSA/GRIGIO	N
P	BLACK	NERO	P
R			R
O			O
S	EXTERNAL SCREEN	SCHERMO ESTERNO	S
T			T

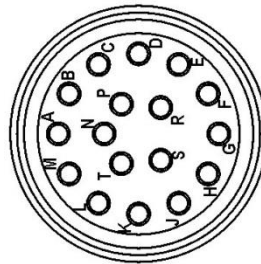

cod. 021.0004.1510

