



WELD THE WORLD

Cruiser Power Pulse

322T
402T
502T

Instruction manual





ENG



INDEX

1	INTRODUCTION	4
1.1	INTRODUCTION.....	5
2	INSTALLATION	6
2.1	CONNECTIONS TO THE ELECTRICAL MAINS NETWORK.....	6
2.2	FRONT PANEL.....	6
2.3	REAR PANEL.....	7
2.4	PREPARING FOR MMA WELDING.....	8
2.5	PREPARING FOR TIG WELDING	9
3	USER INTERFACE	10
4	UNIT POWER-UP	13
5	RESET (LOAD FACTORY SETTINGS)	14
6	SET-UP (INITIAL SET-UP OF THE WELDING POWER SOURCE)	15
7	ALARM MANAGEMENT	18
8	MMA WELDING	20
8.1	TIG WELDING/GOUGING - FIRST LEVEL MENU	20
8.2	MMA /GOUGING WELDING -SECOND LEVEL MENU.....	21
8.3	MMA WELDING - SPECIAL FUNCTIONS	23
9	TIG WELDING	24
9.1	TIG WELDING - FIRST LEVEL MENU	24
9.2	TIG WELDING - SECOND LEVEL MENU	29
9.3	TIG DC WELDING - SPECIAL FUNCTIONS MENU	31
10	TORCH TRIGGER PROCEDURE	34
10.1	2 STROKE SPOT - Q-SPOT FUNCTION	40
11	JOBS MANAGEMENT	45
11.1	SAVING A JOB	45
11.2	DELETING A JOB	46
11.3	LOADING A JOB	47
11.4	SELECTING JOBS USING THE TORCH BUTTONS	47
12	TECHNICAL DATA	48
12.1	CRUISER 322T – POWER PULSE 322T	48
12.2	CRUISER 402T – POWER PULSE 402T	49
12.3	CRUISER 502T – POWER PULSE 502T	50
13	ELECTRICAL DIAGRAM	51
13.1	CRUISER 322T - POWER PULSE 322T	51
13.2	CRUISER 402/502T - POWER PULSE 402/502T	57
13.3	“REMOTE 1” CONNECTOR	62
13.4	“IR” CONNECTOR	62
13.5	TORCH CONNECTOR (front panel).....	62
13.6	REMOTE CONTROL CONNECTOR (back panel).....	62
14	SPARE PARTS	63
14.1	CRUISER 322T - POWER PULSE 322T	63
14.2	CRUISER 402/502T - POWER PULSE 402/502T	65

1 INTRODUCTION

 	<h3>IMPORTANT!</h3> <p><i>This handbook must be consigned to the user prior to installation and commissioning of the unit. Read the "General prescriptions for use" handbook supplied separately from this handbook before installing and commissioning the unit. The meaning of the symbols in this manual and the associated precautionary information are given in the "General prescriptions for use". If the "General prescriptions for use" are not present, it is mandatory to request a replacement copy from the manufacturer or from your dealer. Retain these documents for future consultation.</i></p>
---	---

LEGEND

	<h3>DANGER!</h3> <p><i>This pictogram warns of danger of death or serious injury.</i></p>
---	---

	<h3>WARNING!</h3> <p><i>This pictogram warns of a risk of injury or damage to property.</i></p>
---	---

	<h3>CAUTION!</h3> <p><i>This pictogram warns of a potentially hazardous situation.</i></p>
---	--

	<h3>INFORMATION</h3> <p><i>This pictogram gives important information concerning the execution of the relevant operations.</i></p>
---	--

- ➔ This symbol identifies an action that occurs automatically as a result of a previous action.
- ① This symbol identifies additional information or a reference to a different section of the manual containing the associated information.
- § This symbol identifies a reference to a chapter of the manual.
- *1 The symbol refers to the associated numbered note.

NOTES

The figures in this manual are purely guideline and the images may contain differences with respect to the actual equipment to which they refer.

1.1 INTRODUCTION

This professional and rugged welding power source for DC MMA and TIG welding with exceptional arc characteristics is designed to operate in harsh environmental conditions in the fields of professional maintenance, shipyards and offshore, building construction and heavy fabrication.

The ARC AIR function allows perfect de-seaming with carbon electrodes of up to 10mm in diameter.

Up to 6 mm diameter electrode welding is possible in MMA.

In MMA welding the Hot Start and Arc Force functions are adjustable and they allow improved arc striking, a flatter bead and more uniform weld.

The Anti Sticking function makes it possible to detach the electrode rapidly from the workpiece in the event of accidental sticking.

The parameters pre-set in the DC TIG pulsed synergic curve simplify welding by regulation exclusively of the current.

The current is adjustable also from the Up-Down torch.

The simply and intuitive interface allows high precision adjustments with 50 storable programs.

The wide range of adjustable pulsed frequency in combination with the complementary parameters (base current and duty cycle) makes it possible to weld in slow and fast pulsed mode.

Thanks to its modular configuration, the power source can be configured for MIG/MAG welding by adding a wire feed unit, extension, and, if required, a cooling unit and power source transport trolley.

Fan. The fan is turned on only during welding, at the end of the welding process it remains on for a fixed period of time according to welding conditions.

The fan is nonetheless controlled by specific thermal sensors that guarantee a correct cooling of the machine.

Accessories/ancillary devices that can be connected to the unit:

- UP/DOWN torch or torch with potentiometer to adjust the welding current from a distance.
- Manual remote controller for remote adjustment of the welding current.
- Foot-pedal remote controller for TIG torch arc striking and remote adjustment of welding current.
- ① The maximum and minimum value of the TIP welding current can be set using the remote control pedal. If both remote controls are connected, the remote control pedal takes precedence over the TIG Up/Down or potentiometer torch.
- Liquid cooler group for TIG torches.
- Power source trolley.

Consult your dealer for an updated list of accessories and the latest new products available.

2 INSTALLATION



DANGER! **Lifting and positioning**

Read the warnings highlighted by the following symbols in the "General prescriptions for use".

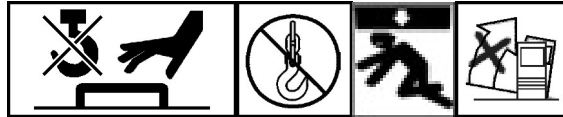

2.1 CONNECTIONS TO THE ELECTRICAL MAINS NETWORK

The mains power supply features to which the equipment should be connected are given in chapter "12 TECHNICAL DATA" at page 48.

The machine can be connected to motorgenerators provided their voltage is stabilised.
Connect/disconnect the various devices with the machine switched off.

2.2 FRONT PANEL

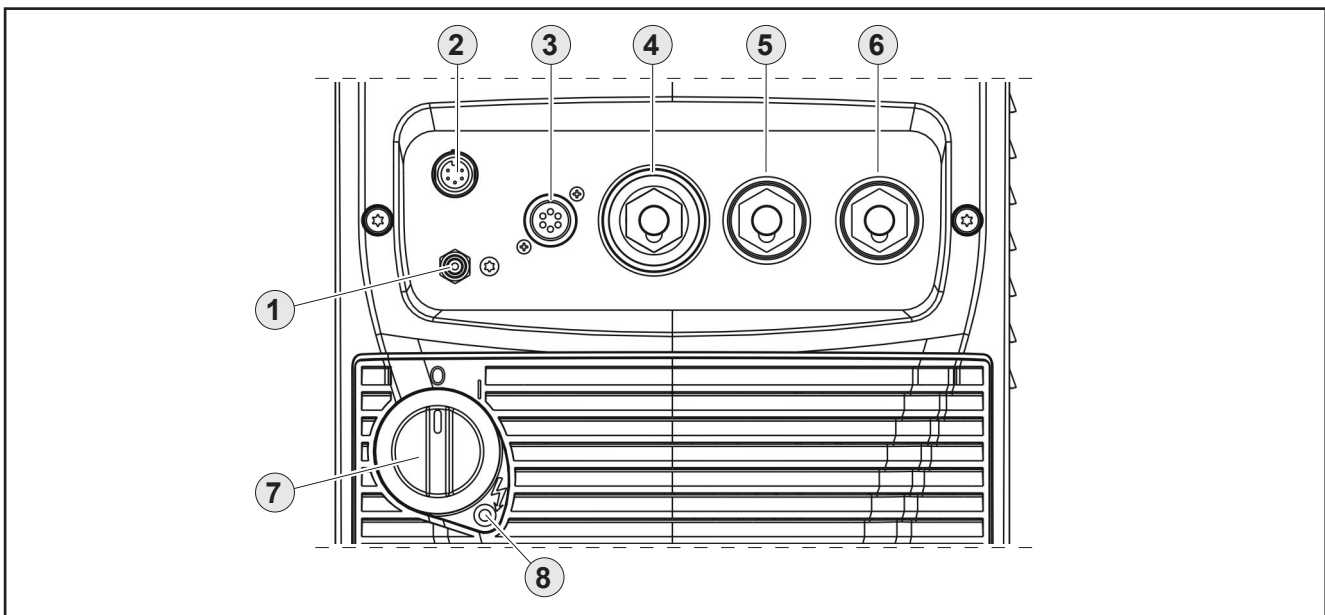

- Connector for gas feed hose: Torch power source [Item 1].
- Connector for logic signals of TIG torch [Item 2].
- Remote controller connector [Item 3].
- TIG TORCH welding socket [Item 4].
- Negative pole welding socket [Item 5].
- Positive pole welding socket [Item 6].
- Welding power source ON/OFF switch. Item 7].
- Mains protection ON LED [Item 8]. This LED illuminates if an incorrect operating condition occurs:
 - absence of a phase in the power supply line.

2.3 REAR PANEL

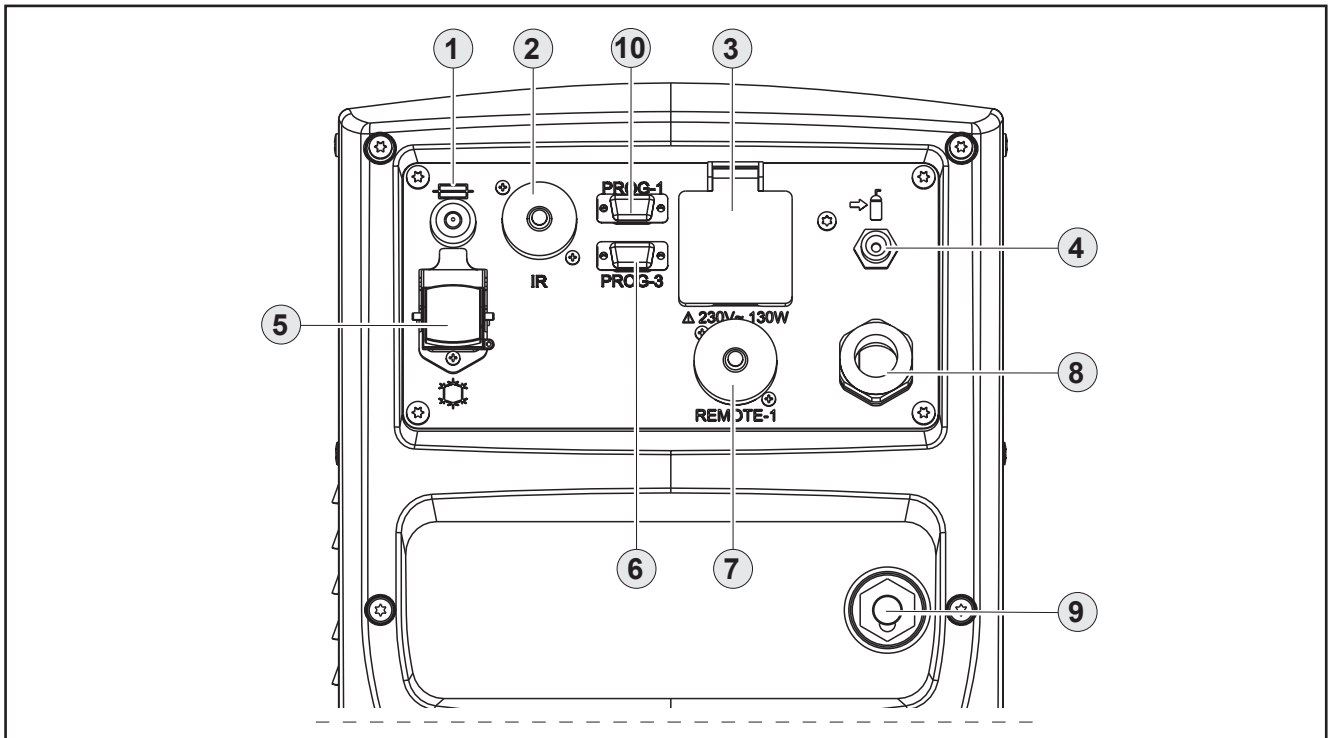

- Auxiliary power supply transformer safety fuse [Item 1].
 - Type: Delayed acting (T)
 - Amperage: 2 A (3.15 A for 322T)
 - Voltage: 500 V a.c.
- Signals connector for automatic application [Item 2].
- Pre-heater supply socket (OPTIONAL on 322T) [Item 3].
The socket is internally protected by a self-resetting fuse.
 - Power socket type: Schuko
 - Maximum power: 130 W
 - Voltage: 230 V a.c.
- Connector for gas feed hose:
 - cylinder power source
- Cooler group power feeding connector [Item 5].
 - Voltage: 400 V a.c.
 - Current output: 1.0 A
 - IP protection rating: IP20 (cap open) / IP66 (cap closed)



DANGER!
High voltage!

If the socket is not connected to any devices always close cap 1

- Connector for connection to the programmer.[Item 6]. (Programming connector for the "frontal logic" circuit board). You can update the software of the equipment using the programming kit.
- Connector of the bundle of cables for connecting the power source to the remote control device. [Item 7].
- Power cable [Item 8].
 - Total length (including internal part): 5,0 m

ENGLISH

- Number and cross section of wires: 4 x 6 mm² (4 mm² on 322T)
- Power plug type: not supplied
- Socket for connecting the power cable between the power source and the remote control device [Item 9].
- (Only Power Pulse 322/402/502T) Connector for connection to the programmer [Item 10]. Programming connector for the “pulsed” circuit board. You can update the software of the equipment using the programming kit.

2.4 PREPARING FOR MMA WELDING

1. Set the welding power source ON/OFF switch to “O” (unit switched off).
2. Plug the power cable plug into a mains socket outlet.
3. Choose the electrode based on the type of material and thickness of the workpiece to be welded.
4. Insert the electrode in the electrode holder.
5. Connect the electrode holder cable to the welding socket based on the polarity requested by the type of electrode used.
6. Connect the plug of the ground clamp to the welding socket on the basis of the polarity required.
7. Connect the earth clamp to the workpiece being processed.



DANGER!

Electric shock hazard!

Read the warnings highlighted by the following symbols in the “General prescriptions for use”.



8. Set the welding power source ON/OFF switch to “I” (unit powered).
 9. Select the following welding mode on the user interface: MMA
 10. Set the required welding parameter values on the user interface.
- ➡ When the remote controller [RC] is connected and the relative locking screw is tightened, welding current can be adjusted using the remote controller.

The system is ready to start welding.

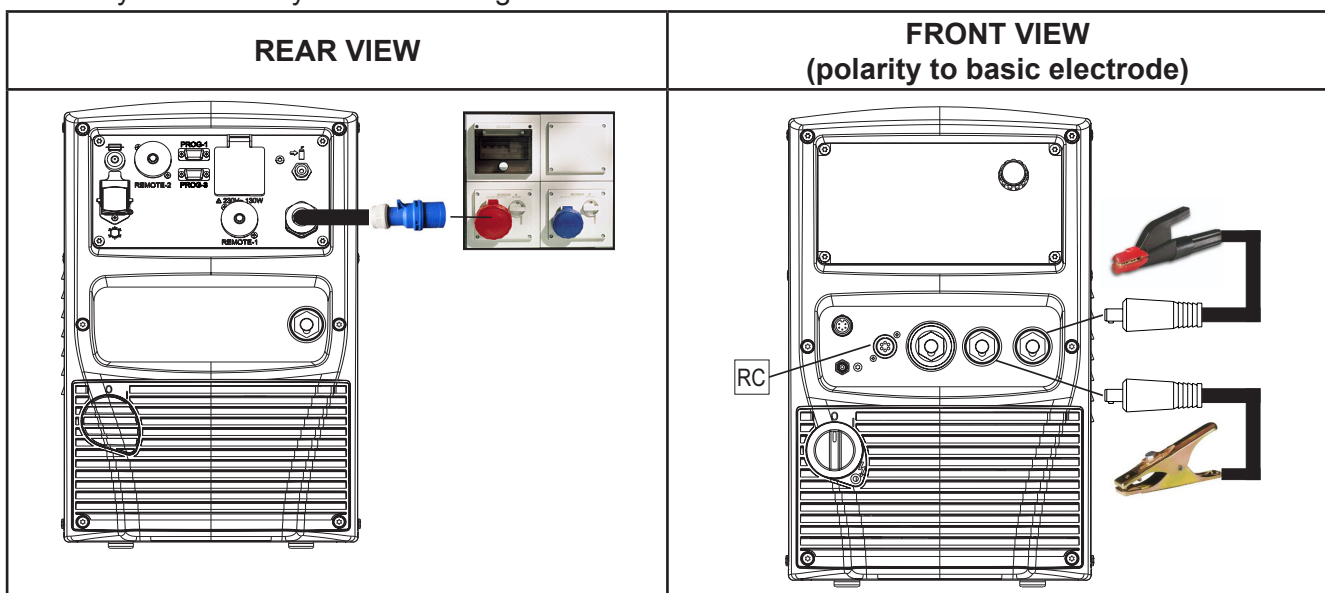

2.5 PREPARING FOR TIG WELDING

NOTE: For the cooler to power source assembly procedure refer to the cooler instruction manual.

1. Set the welding power source ON/OFF switch to "O" (unit de-energized).
 2. Plug the power cable plug into a mains socket outlet.
 3. Connect the gas hose from the welding gas cylinder to the rear gas socket.
 4. Open the cylinder gas valve.
 5. Choose the electrode based on the type of material and thickness of the workpiece to be welded.
 6. Insert the electrode in the TIG torch.
 7. Connect the torch plug to the welding socket on the basis of the polarity required by the type of electrode in question.
 8. Connect the plug of the ground clamp to the welding socket on the basis of the polarity required.
 9. Connect the gas hose from the welding torch to the front gas socket.
 10. Connect the welding torch connector to the TIG torch signals connector.
 11. Connect the earth clamp to the workpiece being processed.
 12. Set the welding power source ON/OFF switch to "I" (unit powered).
 13. Select the following welding mode on the user interface: DC TIG
 14. Press the torch trigger with the torch well clear of any metal parts. This serves to open the gas solenoid valve without striking the welding arc.
 15. Use the flow control valve to adjust the flow of gas as required while the gas is flowing out.
 16. Set the required welding parameter values on the user interface.
- ➡ When the remote control pedal is connected and the relative locking screw is tightened the welding current will vary in relation to the pressure exerted on the pedal.

The system is ready to start welding.

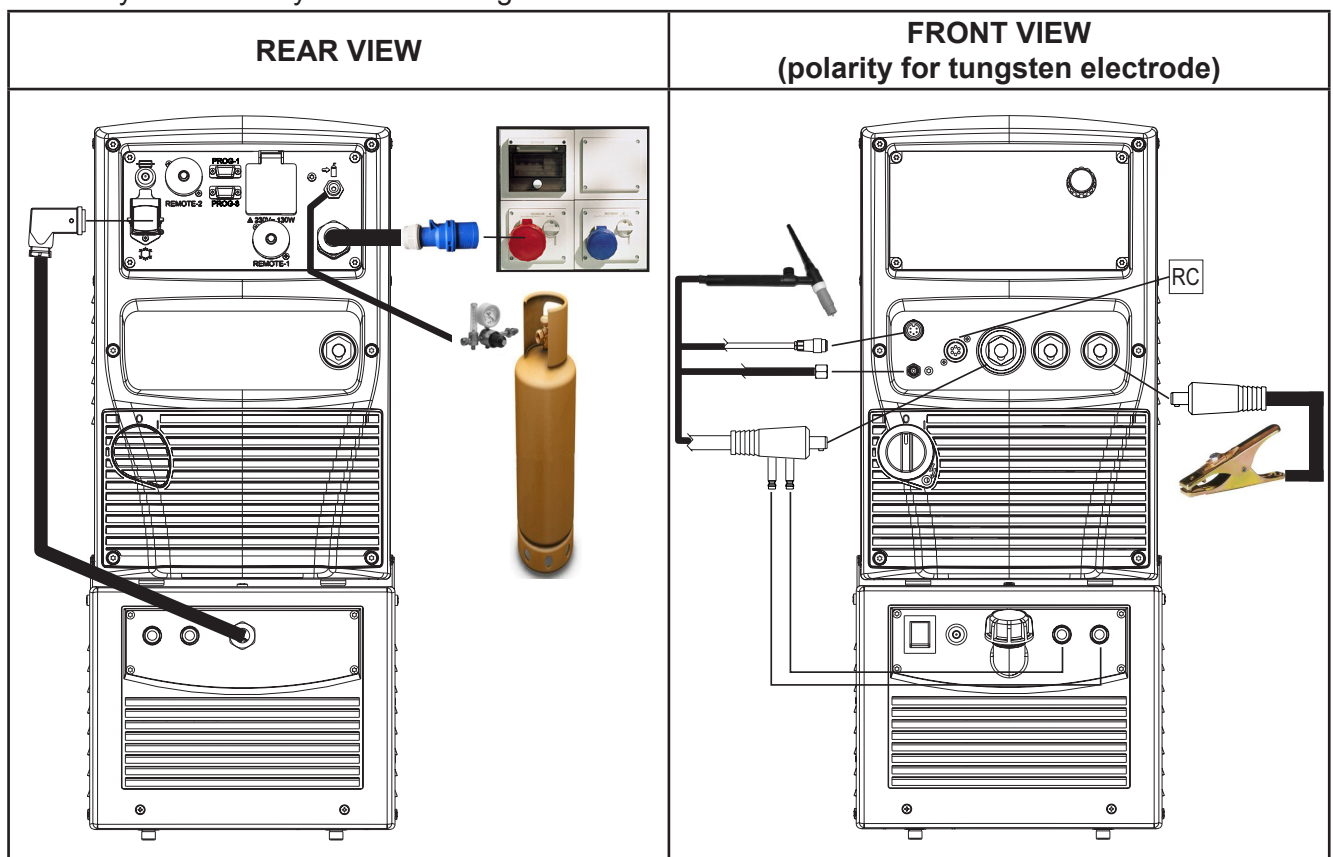

3 USER INTERFACE



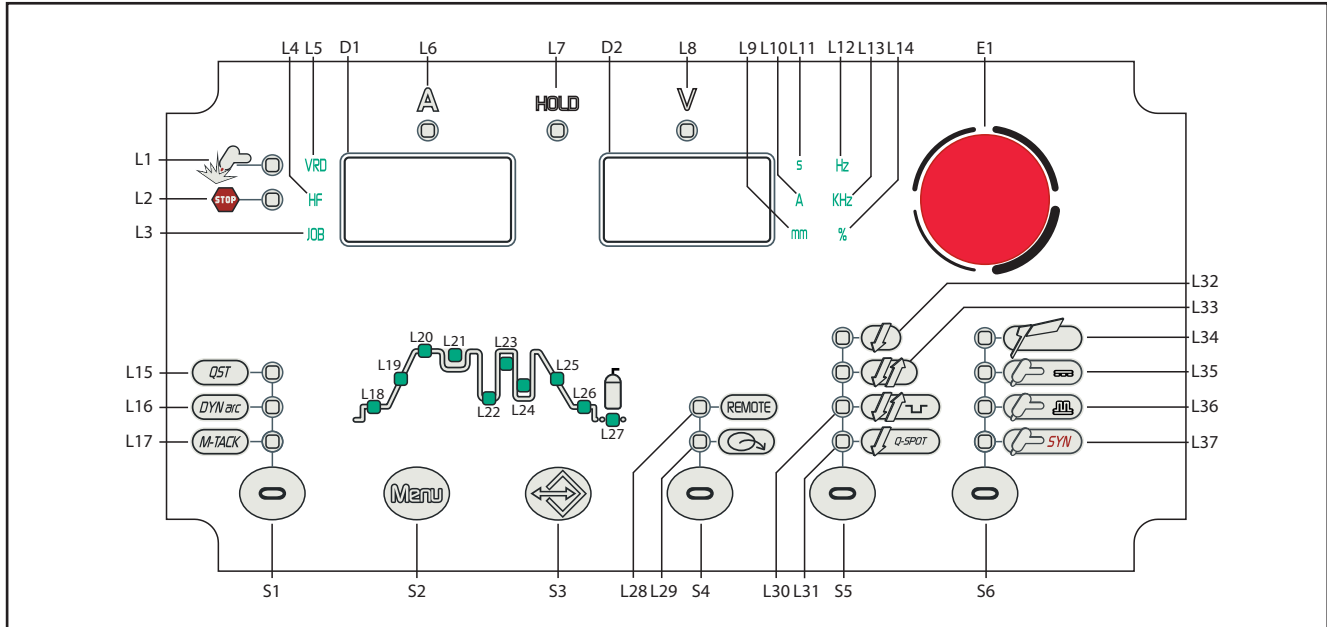



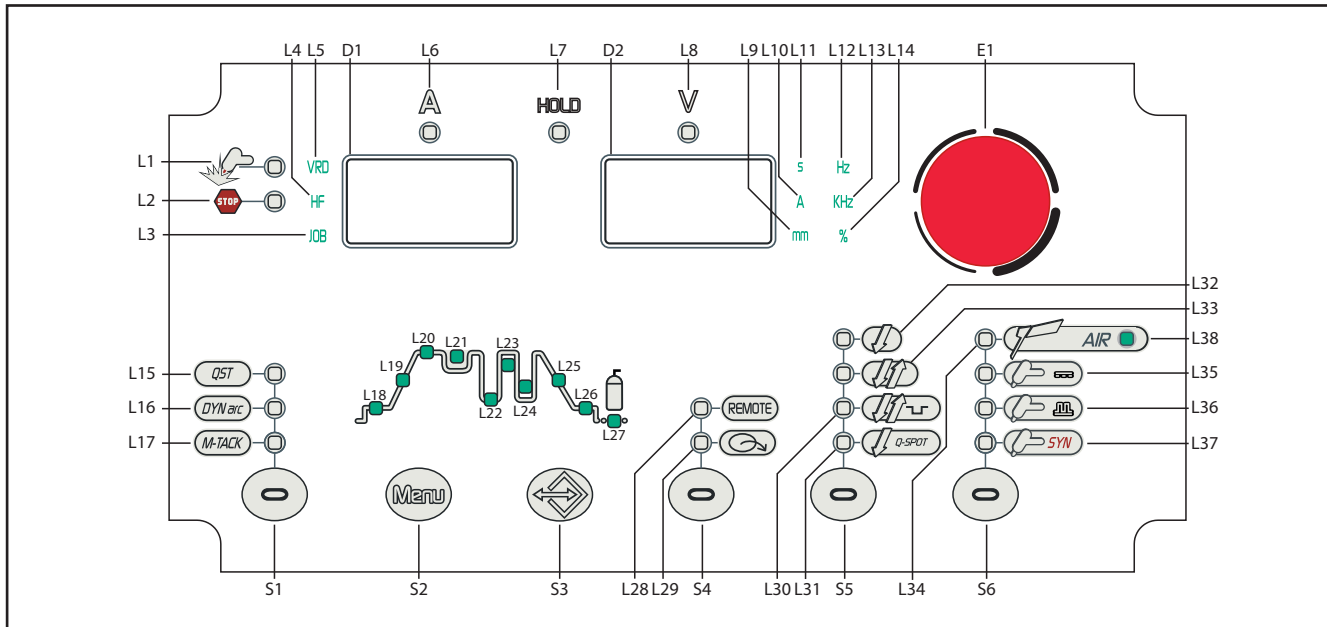

Cruiser 322T - Power Pulse 322T























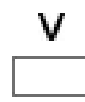

Cruiser 402-502T - Power Pulse 402-502T



CODE	SYMBOL	DESCRIPTION
L1		This LED illuminates to confirm the presence of power on the output sockets.
L2		This LED illuminates to show an anomaly in the operating conditions.
L3	JOB	Illuminates to show that a previously saved JOB has been loaded.

CODE	SYMBOL	DESCRIPTION
L4	HF	Illumination shows that the following function has been activated: HIGH FREQUENCY ARC STRIKE (HF)
L5	VRD	Illumination shows that the following function has been activated: VRD (reduced output voltage). The no-load voltage between the welding sockets is switched from U0 to Ur (see technical data).
L6	A	Illuminates to indicate a value in the following unit of measurement: AMPERES
L7	HOLD	Illuminates to show the last voltage and current values measured during welding. The value appears on the following displays: D1-D2 The LED switches off when a new welding procedure is started, or when any of the welding settings is modified.
L8	V	Illuminates to indicate a value in the following unit of measurement: VOLTS (V)
L9	mm	Illuminates to indicate a value in the following unit of measurement: MILLIMETERS (mm)
L10	A	Illuminates to indicate a value in the following unit of measurement: AMPERES (A)
L11	S	Illuminates to indicate a value in the following unit of measurement: SECONDS (s)
L12	Hz	Illuminates to indicate a value in the following unit of measurement: HERTZ (Hz)
L13	KHz	Illuminates to indicate a value in the following unit of measurement: KILOHERTZ (KHz)
L14	%	Illuminates to indicate a value in the following unit of measurement: PERCENTAGE (%)
L15	QST	When this LED illuminates the following parameter can be set: Q-START
L16	DYN arc	When this LED illuminates the following parameter can be set: DYNAMIC ARC
L17	M-TACK	When this LED illuminates the following parameter can be set: MULTI TACK
L18		When this LED illuminates the following parameter can be set: STARTING CURRENT (%/A)
L19		When this LED illuminates the following parameter can be set: SLOPE UP (s)
L20		When this LED illuminates the following parameter can be set: WELDING CURRENT (A)
L21		When this LED illuminates the following parameter can be set: SECOND CURRENT B-LEVEL (%)
L22		When this LED illuminates the following parameter can be set: BASE CURRENT (A)
L23		When this LED illuminates the following parameter can be set: PEAK TIME (s)
L23+L24		When this LED illuminates the following parameter can be set: PULSED CURRENT FREQUENCY (Hz/kHz)
L24		When this LED illuminates the following parameter can be set: BASE TIME(s)

CODE	SYMBOL	DESCRIPTION
L25		When this LED illuminates the following parameter can be set: SLOPE DOWN (s)
L26		When this LED illuminates the following parameter can be set: /STARTING CURRENT (%/A)
L27		When this LED illuminates the following parameter can be set: POST-GAS (s)
L28	REMOTE	Illuminates to signal activation of a connected remote control unit, if available.
L29		This LED indicates that the current reference setting is imposed by the remote controller.
L30		Illumination shows that the following function has been activated: 4 stroke B-level procedure + high frequency arc strike (HF).
L31		Illumination shows that the following function has been activated: 2 stroke spot procedure (Q-SPOT).
L32		Illumination shows that the following function has been activated: 2 stroke procedure.
L33		Illumination shows that the following function has been activated: 4 stroke procedure.
L34		This LED illuminates to show that the following welding mode is selected: MMA
L35		This LED illuminates to show that the following welding mode is selected: TIG DC CONTINUOUS
L36		This LED illuminates to show that the following welding mode is selected: PULSED DC TIG
L37		This LED illuminates to show that the following welding mode is selected: SYNERGIC PULSED DC TIG When this is on, it means that the synergic mode is active and that the operator can set just the welding current while the other parameters are automatically regulated by the machine. The synergy is optimised by angle welding.
L38		This LED illuminates to show that the following welding mode is selected: GOUGING ELECTRODE (Only on 402-502)
D1		Data setting: The display shows the acronym of the parameter to be set. Welding: The display shows the effective amperes value during welding. HOLD function: The display shows the average current value measured over the entire welding period (excluding the starting and ending ramps).
D2		Data setting: The display shows the value of the selected parameter. Welding: The display shows the effective voltage during welding operations. HOLD function: The display shows the average voltage value measured over the entire welding period (excluding the starting and ending ramps).
S1		Press the button to select the parameter to be set. Possible choices: Q-START - DYNAMIC ARC - MULTI TACK AC TIG mode: Press the button to select the parameter to be set. Possible choices: MIX AC - EXTRA FUSION - AC FREQUENCY – AC BALANCE - ELECTRODE DIAMETER
S2		Press and release: the button selects the first level menu parameters. Hold down for 3 seconds: the button opens the second level menu. When in the menu, press and release the button to select the parameters. Keep the button pressed while powering on the power source: the button opens the SETUP menu.
S3		Press and release: the button opens the JOBS upload menu. Hold down for 3 seconds: the button opens the JOBS save and delete menu.

CODE	SYMBOL	DESCRIPTION
S4		Press and release: the button enables the device to receive the welding current control signal from a remote controller. Hold down for 3 seconds: the button activates a connected remote controller, if available, which is then used to manage all functions of the welding power source from a distance.
S5		TIG DC / TIG AC mode: This button selects the torch trigger procedure. MMA mode: Press the button to show the selected electrode type for MMA welding.
S6		This button selects the welding mode.
E1		Data setting: The encoder sets the value of the selected parameter. Welding: The encoder sets the value of the following parameter: WELDING CURRENT

4 UNIT POWER-UP

Set the welding power source ON/OFF switch to “I” to switch on the unit.

FX.X The message appears on the following display: **D2**.

x.x= software version

First power-up or power-ups following a RESET procedure

The welding power source sets up for welding with the factory pre-sets.

Subsequent power-ups

The welding power source sets up for welding in the latest stable welding configuration that was active at the time of power-off.

5 RESET (LOAD FACTORY SETTINGS)

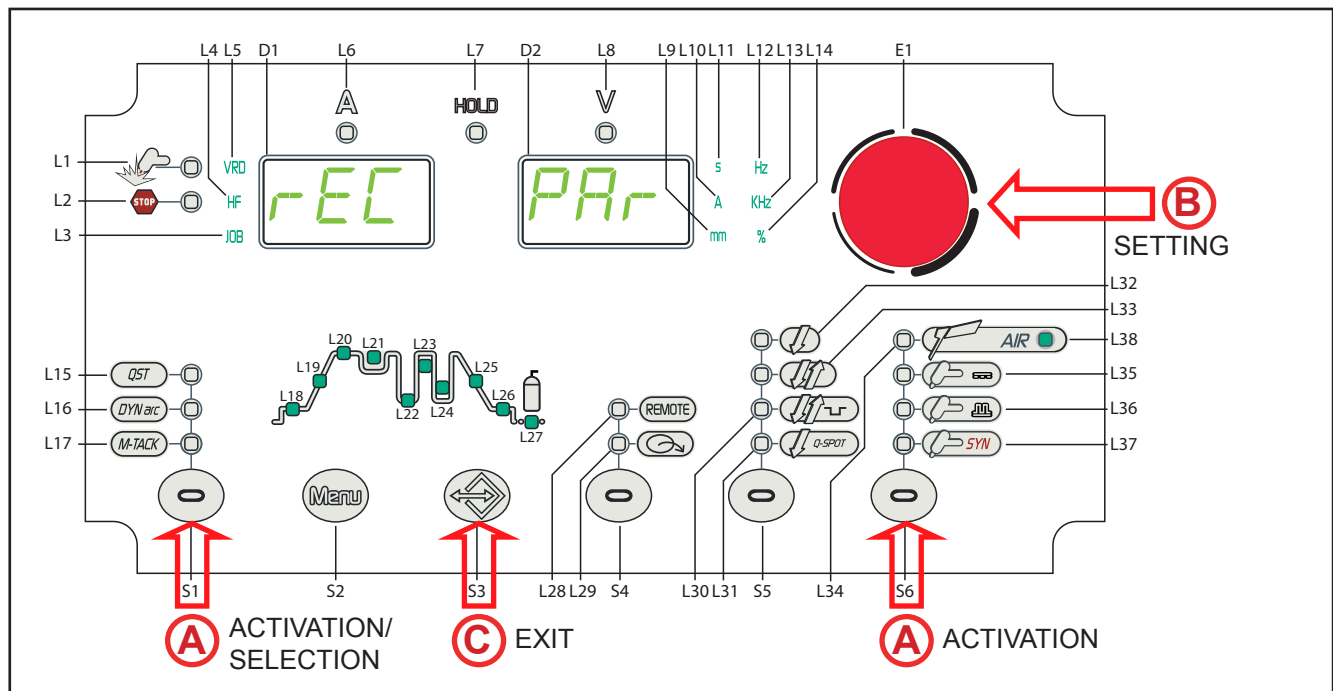

The reset procedure involves complete restoration of the default values, parameters and memory settings set in the factory.

The reset procedure is useful in the following cases:

- Too many changes made to the welding parameters so user finds it difficult to restore defaults.
- Unidentified software problems that prevent the welding power source from functioning correctly.

PARTIAL RESET

The reset procedure involves restoration of the parameter values and settings, except the following settings:



- Settings of the SETUP menu.
- Saved JOBS.

TOTAL RESET

The reset procedure involves complete restoration of the default values, parameters and memory settings set in the factory.



All memory locations will be reset and hence all your personal welding settings will be lost!

(A)	<ul style="list-style-type: none"> o Set the welding power source ON/OFF switch to "O" to switch the unit off. o Keeping both the S1 and S6 buttons pressed, set the generator power source switch to "I" to turn on the equipment [SIMULTANEOUS ACTIONS] - rEC PAR: The message appears on the following displays: D1-D2.
(B)	<ul style="list-style-type: none"> o Select encoder E1 with the following setting: rEC PAR (partial) or rEC FAC (total).

- (C)**
- **Exit with confirmation**
 - Press the **S3**  button.
 - Wait for the memory clear procedure to terminate. This action will automatically close the menu.
 - **Exit without confirmation**
 - Press any  button (**except S3**).
 - This action will automatically close the menu.

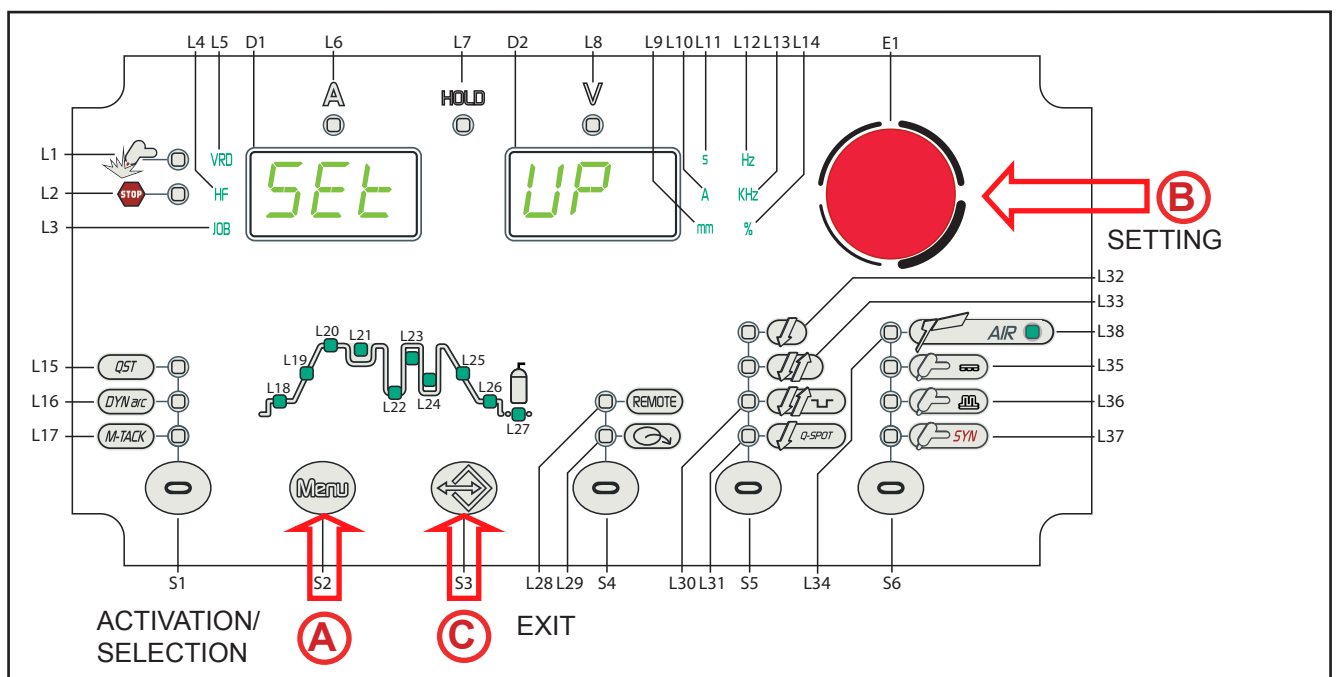
6 SET-UP (INITIAL SET-UP OF THE WELDING POWER SOURCE)



- (A)**
- Set the welding power source ON/OFF switch to “O” to switch the unit off.
 - Holding the **S2**  button down, turn the power source switch to “I” to start the equipment.
 - [⚠ SIMULTANEOUS ACTIONS]**
 - **SEt UP** : The message appears for a few seconds on the following displays: **D1-D2**.
 - **Coo Aut**: The message appears on the following displays: **D1-D2**.
 - Use the **S2**  button to scroll through the settings to be modified.

- (B)**
- Using the **encoder E1** , edit the value of the selected setting.

- (C)**
- **Exit with confirmation**
 - Press any button (**except S2**) for example **S3** .
 - This action will automatically close the menu.

Tab. 1 - Setup settings

ACRONYM	SETTING	MIN	DEFAULT	MAX
Coo	COOLER ACTIVATION	Aut	Aut	oFF
St.C.	STARTING CURRENT	%	%	A
F.Cu.	FINAL CURRENT	%	%	A
HF.C.	HF CURRENT	20 A	SYn	250 A
HF.t.	HF TIME	0.5 s	2.0 s	3.0 s
PUL.	TYPE OF PULSED CURRENT	SLo.	FA.	FA.
P.A.	PILOT ARC	oFF	on	on
E.C.C.	CONTACT COMMAND EXPANSION	oFF	oFF	on
E.r.C.	ENABLE READ CURRENT	oFF	on	on
StS	SPECIAL TORCH STROKE	oFF	oFF	2
F.r.C.	UP CURRENT	2	2	9

- Coo [COOLER ACTIVATION GROUP]

- ON= The cooler is always running when the power source is switched on. This mode is preferable for heavy duty and automatic welding procedures.
- OFF= The cooler is always disabled because an air-cooled torch is in use.
- AUT= When the unit is switched on the cooler is switched on for 15s. During welding procedures the cooler runs constantly. When welding is terminated the cooler continues to run for 90s + a number of seconds equivalent to the average current value shown using the HOLD function.

Torch loading



WARNING!

Make sure the torch in use is correctly sized in relation to the welding current required and for the available and selected cooling type. This prevents the risk of burns to which the operator is potentially exposed, potential faults, and irreversible damage to the torch and the system. If a torch is installed or replaced while the unit is running, the circuit of the newly installed torch must be filled with coolant to avoid the risk of damage to the torch in the case of high voltage arc strikes without any liquid in the circuit.

Power-up with operation of the cooler set to "ON" or "AUT" mode

- A check is performed automatically of the presence of liquid in the cooling circuit and the cooler is switched on for 15 seconds.
- If the coolant circuit is full, the power source sets up in the most recent stable welding configuration.
- If the coolant circuit is not full, all functions are inhibited and there will be no output power present.

AL. Coo. : The message appears on the following displays: **D1-D2.**



Press any button to repeat the checking procedure for an additional 15seconds.
If the problem persists, rectify the cause of the alarm.

Power-up with operation of the cooler set to "OFF"

Operation of the cooler and the cooler alarm are disabled.
Welding is performed without liquid cooling of the torch.

Torch change-over with operation of the cooler set to "ON"

Press and release the torch trigger.

This serves to start the cooler for 15 seconds to fill the torch cooling circuit.

- St.C. [STARTING CURRENT]

- The value of this parameter can be set as a percentage of the welding current or as an absolute value expressed in Amperes.

F.C. [FINAL CURRENT]

- The value of this parameter can be set as a percentage of the welding current or as an absolute value expressed in Amperes.

- HF.C. [HF CURRENT]

- This parameter establishes the current value during HF discharge. The value of this parameter can be set as an absolute value or in SYN.
- With SYN setting the HF current value is calculated automatically on the basis of the pre-set welding current value.

Consequences of a higher value:

- Arc striking is facilitated, even on very dirty workpieces.
- Risk of piercing excessively thin gauge workpieces.

- HF.t. [HF TIME]

- This parameter defines the maximum high frequency (HF) arc strike duration.

- PUL. [TYPE OF PULSED CURRENT]

- SLo. = This setting enables slow pulsed mode. The peak time and base time are set.
- FA.= This setting enables fast pulsed mode. The frequency and duty-cycle are set.

- P.A. [PILOT ARC]

- The function enables the output of a low current between the 1st and 2nd times of the torch trigger to shield the mask in advance and avoid the risk of blinding flashback caused by the welding current.

- C.C.E CONTACT COMMAND EXPANSION

- The function enables the emission of the ARC-ON and ALARM signals via the signal connectors for automatic applications.

- E.r.C. [ENABLE READ CURRENT]

- This function allows for the real welding current display to be enabled or disabled.

- StS [SPECIAL TORCH STROKE]

- The parameter changes the torch trigger operating mode.
 - oFF: indicates standard operation.
 - 1: specifies the 4T B-level management variant. Allows the transition to the secondary welding current by pressing and holding down the UP or DOWN button; when the button is released, the primary current is restored. With variant oFF selected, the UP/DOWN buttons are disabled for all procedures.
 - 2: specifies the down slope management variant. By releasing the torch trigger during the third stroke (3S) the down slope is stopped and the final current is immediately delivered without having to go through the entire slope time.

- F.r.C. [COMMAND TYPE PEDAL]

- The parameter selects the type of pedal used:
 - RC02 standard pedal type
 - RC09 special pedal type. This type of pedal recognises the pressure applied to the foot pedal

or the torch button, switching automatically from internal adjustment to external control using the pedal.

- I.UP [UP CURRENT]

- When the parameter is set to ON, the maximum value of the welding current that can be set with the UP / DOWN torch is the current set by the encoder in the front panel of the welding power source. When the parameter is set to OFF, the maximum value of the welding current that can be set with the UP / DOWN torch is the maximum current that can be supplied by the welding power source.

7 ALARM MANAGEMENT



This LED illuminates if an incorrect operating condition occurs.

An alarm message appears on the following display: **D2**.

Tab. 2 - Alarm messages

MESSAGE	MEANING	EVENT	CHECKS
AL. HEA.	In start-up phase	Appears for 2-3 seconds	
	Overheating alarm Indicates tripping of the welding power source thermal protection. Leave the unit running so that the overheated components cool as rapidly as possible. When the unit has cooled, the welding power source will reset automatically.	All functions disabled. <u>Exceptions:</u> • Cooling fan. • Cooler (if switched on).	<ul style="list-style-type: none"> • Make sure that the power required by the welding process is lower than the maximum rated power output. • Check that the operating conditions are in compliance with the welding power source data plate specifications. • Check for the presence of adequate air circulation around the welding power source.
	Phase missing alarm Indicates the absence of a phase in the power supply line. The message appears at the same time as the mains protection activation LED switches on.	All functions disabled. <u>Exceptions:</u> • Cooling fan.	<ul style="list-style-type: none"> • Check if the equipment power supply line has all the phases. <p><u>If the problem persists:</u></p> <ul style="list-style-type: none"> • qualified technical personnel are required for repair/maintenance jobs.
AL. Coo.	Cooler alarm Indicates insufficient pressure in the torch liquid cooling circuit.	All functions disabled. <u>Exceptions:</u> • Cooling fan. The alarm message persists on the display until the first operation is performed on the user interface. <u>Signalling of the alarm depends on the following settings:</u> • Coo = on: the alarm is signalled if the cooling unit is connected to the power source and if it is running. • Coo = oFF: the alarm is never signalled, irrespective of the circumstances. • Coo = Aut: the alarm is signalled if the cooling unit is connected to the power source and if it is running.	<ul style="list-style-type: none"> • Check that the connection to the cooler is correct. • Check that the "O/I" switch is set to "I" and that it illuminates when the pump is running. • Check that the cooler is filled with coolant. • Check that the cooling circuit is liquid tight, notably the torch hoses, the fuse and the internal connections of the cooler.

MESSAGE	MEANING	EVENT	CHECKS
E. 69	Software compatibility error Indicates that the welding power source has a software version that is not compatible with the remote device connected to it (remote controller, wire feed unit).	All functions disabled. <u>Exceptions:</u> • Cooling fan.	<ul style="list-style-type: none"> • Update the remote device software. • Contact support
E. 04	Alarm, no-load voltage failure	All functions disabled. <u>Exceptions:</u> • Cooling fan	<ul style="list-style-type: none"> • Check to ensure the welding torch is not resting on the work-piece connected to ground. • Check that when the power source is switched on there is no short circuit between the sockets (voltage must be greater than/equivalent to U_r). <p><u>If the problem persists:</u></p> <ul style="list-style-type: none"> • Qualified technical personnel are required for repair/maintenance jobs.
E. 05	Torch button alarm Indicates that when the power source was powered up a short circuit was detected on the torch trigger input. When the unit has cooled, the welding power source will reset automatically.	All functions disabled. <u>Exceptions:</u> • Cooling fan.	<ul style="list-style-type: none"> • Make sure the torch trigger is not pressed, jammed, or short circuiting. • Make sure the torch and torch connector are intact.
CAn Err.	No communication alarm Indicates the presence of problems in data communication between the power source and wire feeder. When the unit has cooled, the welding power source will reset automatically. Exit the alarm state by performing one of the following actions: Switch the power source off.	All functions disabled. <u>Exceptions:</u> • cooling fan. • cooler (if switched on).	<ul style="list-style-type: none"> • Check that the connecting cable between power source and wire feeder is intact and make sure the connectors are securely tightened. <p><u>If the problem persists:</u></p> <ul style="list-style-type: none"> • qualified technical personnel are required for repair/maintenance jobs.

8 MMA WELDING

8.1 TIG WELDING/GOUGING - FIRST LEVEL MENU

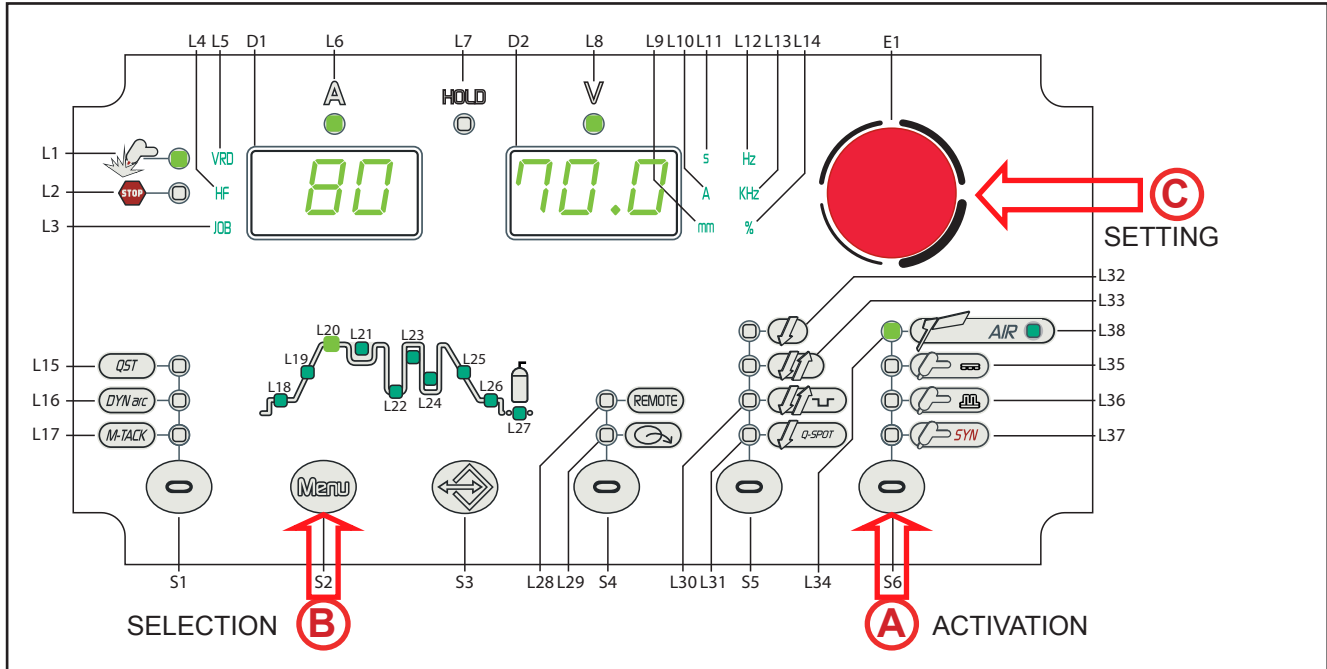

- Press the **S6** (A) button to activate the MMA or GOUGING mode.

(A)

L 36 MMA
L 37 GOUGING
- Press the **S2** (B) button to scroll the list of settings to edit.
 - The acronym relative to the setting to be edited appears on the following displays: **D1**.
 - The value relative to the selected setting appears on the following displays: **D2**.
- Using the **encoder E1** (C), edit the value of the selected setting. The value is saved automatically.

Tab. 3 - Parameters of the 1st level menu: MMA/GOUGING mode

ACRONYM	SETTING	MIN	DEFAULT	MAX	NOTES
-	WELDING CURRENT MAXIMUM CURRENT WITH REMOTE CONTROLLER	10 A	80 A	MAX A	MAX: Maximum value of welding current
Ho.S.	HOT-START	0 %	*SYn	100 %	Only MMA
Ar.F.	ARC FORCE	0 %	*SYn	250 %	Only MMA

Press any key (except S2) to save the setting and exit the menu.

- WELDING CURRENT

- o This parameter regulates the primary welding current value.

- MAXIMUM CURRENT WITH REMOTE CONTROLLER

- o The maximum output current value that can be achieved with foot pedal controller external reference.

- HOT-START



- o This parameter aids electrode melting at the time of arc striking. It is set as a percentage referred to the value of the following parameter: **WELDING CURRENT**. The value is limited to 250A max.
 - Consequences of a higher value:
 - Ease of activation; Greater starting spatter; increase in the activation area.
 - Consequences of a lower value:
 - Difficulty of activation; Less starting splatter; Reduction in the activation area.

- ARC FORCE

- o This parameter helps to avoid electrode sticking during welding. It is set as a percentage referred to the value of the following parameter: **WELDING CURRENT**
 - Consequences of a higher value:
 - Fluency factors in welding; Arc welding stability; Increased melting of the electrode within the workpiece; More weld spatter.
 - Consequences of a lower value:
 - The arc is extinguished more easily, less welding spatter.

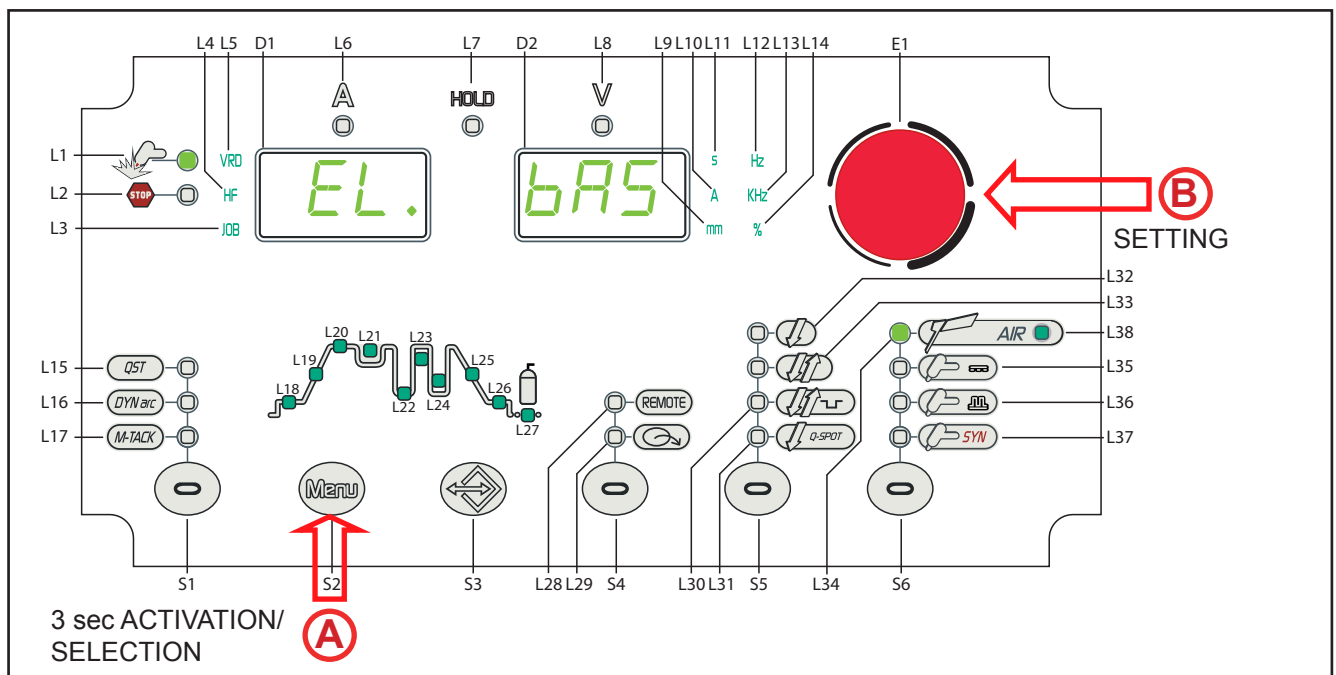
8.2 MMA /GOUGING WELDING -SECOND LEVEL MENU



- A**
 - Hold down the **S2**  button for 3 seconds to access the 2nd level menu.
 - The acronym relative to the setting to be edited appears on the following displays: **D1**.
 - The value relative to the selected setting appears on the following displays: **D2**.
 - Press the **S2**  button to scroll the list of settings to edit.
- B**
 - Using the encoder **E1** , edit the value of the selected setting. The value is saved automatically.

Tab. 4 - Parameters of the 2nd level menu: MMA mode

ACRONYM	SETTING	MIN	DEFAULT	MAX	NOTES
EL.	ELECTRODE TYPE	bAS	bAS	bAS= basic rUt= rutile Crn= chromium/nickel ALU= aluminium	Only MMA
Urd	OUTPUT VOLTAGE REDUCTION	oFF	oFF	on	
U.EL.	LONG ARC VOLTAGE	37	*SYn	70	Only MMA

Press any key  (except **S2**) to save the setting and exit the menu.

- ELECTRODE TYPE

- This parameter allows for the selection of the type of electrode to be used. The selection automatically allows the optimum welding parameters to be set.

- VRD

- This parameter reduces the potential across the welding sockets when welding is not in progress.
 - The arc strike procedure is as follows:
 - Touch the workpiece with the electrode tip.
 - Raise the electrode.
 - Power is released for several seconds.
 - Touch the workpiece with the electrode tip.
 - The welding arc will strike.

- LONG ARC VOLTAGE

- This parameter inhibits power output when the potential between electrode and workpiece exceeds the pre-set threshold level.
 - Consequences of a higher value:
 - The welding arc is kept triggered also with the electrode detached from the workpiece being soldered.
 - Consequences of a lower value:
 - Faster exit from weld.

***SYN:** This code indicates that parameter control is synergic. The optimal value of this parameter is set automatically by the microprocessor on the basis of the pre-set welding current value.

- When SYN is installed, to display the synergic value press the following button: **S5**.
- This value can be displayed but it is not user-adjustable.

8.3 MMA WELDING - SPECIAL FUNCTIONS

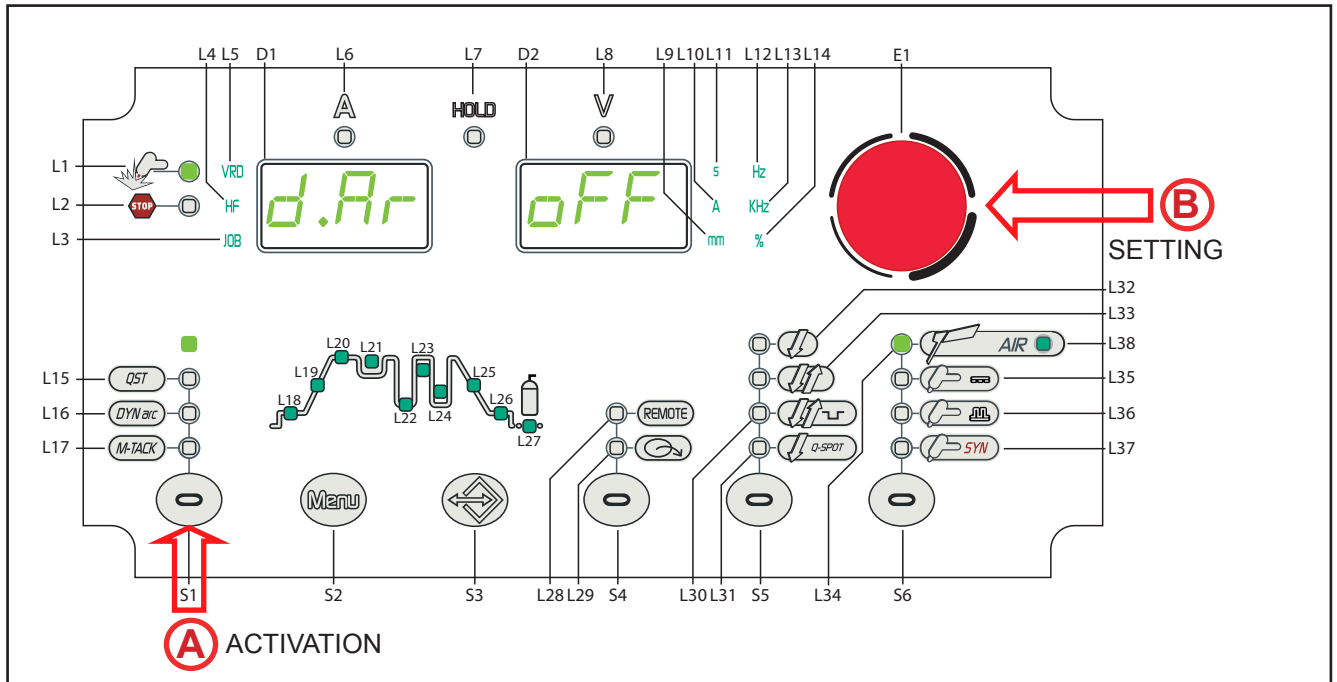

- (A)** ○ Press the **S1** (○) button to activate the special function.
 - The acronym relative to the setting to be edited appears on the following displays: **D1**.
 - The value relative to the selected setting appears on the following displays: **D2**.
- (B)** ○ Using the **encoder E1** (○), edit the value of the selected setting. The value is saved automatically.

Tab. 5 - Special functions in MMA mode

ACRONYM	SETTING	MIN	DEFAULT	MAX	NOTES
d.Ar.	DYNAMIC ARC	oFF	oFF	on	Only MMA

Press any key (○) (except **S1**) to save the setting and quit the menu.

- DYNAMIC ARC

- Welding power remains constant even when the distance between electrode and workpiece changes.
- Consequences of a higher value:
 - Prevents electrode bonding; Thin gauge sheets are easily distorted.

9 TIG WELDING

9.1 TIG WELDING - FIRST LEVEL MENU

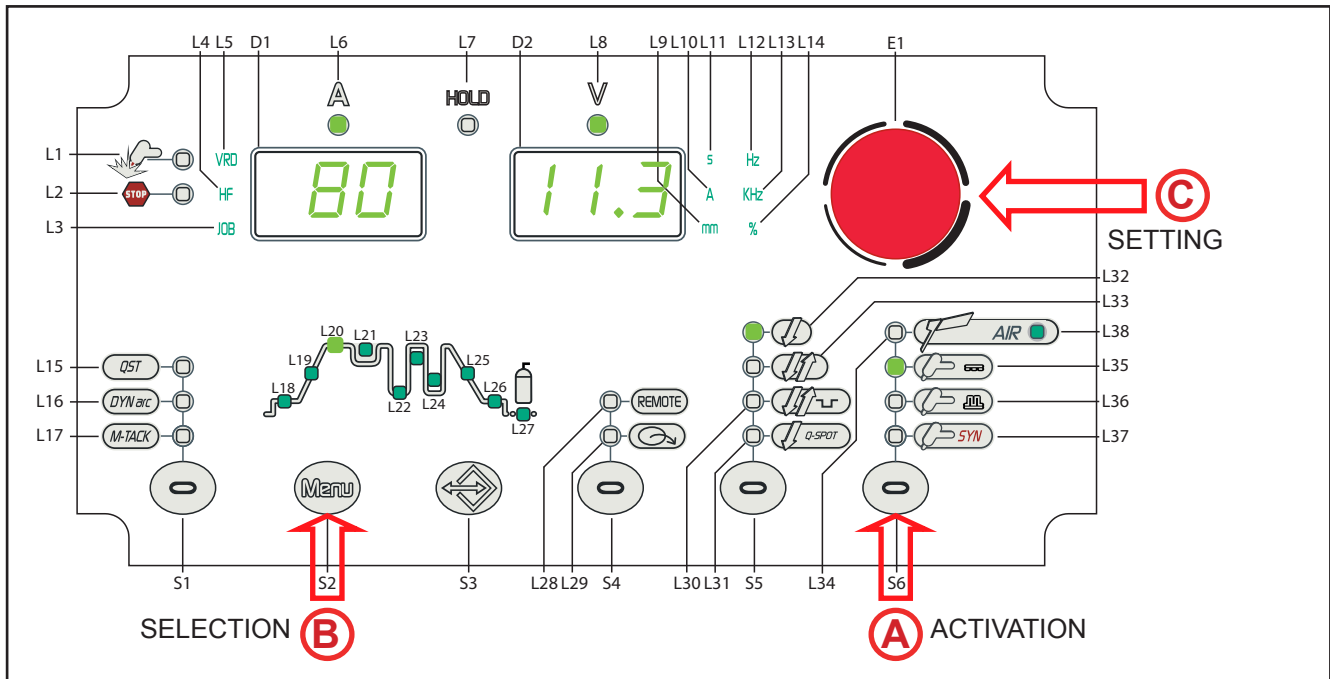

- A
 - o Press the **S6** button to activate the TIG mode.
- L 35 TIG DC CONTINUOUS**
L 36 TIG DC PULSED
L 37 SYNERGIC PULSED DC TIG
- B
 - o Press the **S2** button to scroll the list of settings to edit.
 - The acronym relative to the setting to be edited appears on the following displays: **D1**.
 - The value relative to the selected setting appears on the following displays: **D2**.
 - C
 - o Using the **encoder E1**, edit the value of the selected setting. The value is saved automatically.

Press any key (except S2) to save the setting and exit the menu.

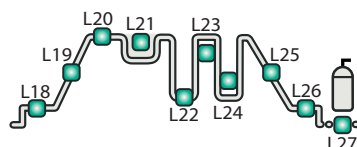

Tab. 6 - Parameters of the 1st level menu: TIG DC, CONTINUOUS and TIG AC mode:

ACRONYM	SETTING	MIN	DEFAULT	MAX	USEFUL ADVICE
Pr.G.	PRE-GAS TIME	0.0 s	0.1 s	10.0 s	Recommended value 0-3s
St.C. (L 18)	STARTING CURRENT	5 A	50 A	500 A	Recommended value 30% or 15A
		2 %	50 %	200 %	
Sl.u. (L 19)	SLOPE UP	0.0 s	0.0 s	25.0 s	Recommended value 0-1s
- (L 20)	WELDING CURRENT MAXIMUM CURRENT WITH REMOTE CONTROLLER	5 A	80 A	MAX A	MAX: Maximum value of welding current
S.Cu. (L 21)	SECOND CURRENT B-LEVEL	10 %	50 %	200 %	
Sl.d. (L 25)	DOWN SLOPE	0.0 s	0.0 s	25.0 s	Recommended value 0-5s
F.Cu. (L 26)	FINAL CURRENT	5 A	5 A	MAX A	MAX: Maximum value of welding current Recommended value 30%
		5 %	5 %	80 %	
Po.G. (L 27)	POST GAS TIME	0.0 s	10.0 s	25.0 s	Recommended value 8-0s

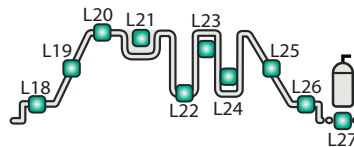

Tab. 7 - Parameters of the 1st level menu: PULSED TIG DC mode, SYNERGIC PULSED TIG DC mode and PULSED TIG AC mode

ACRONYM	SETTING	MIN	DEFAULT	MAX	USEFUL ADVICE
Pr.G.	PRE-GAS TIME	0.0 s	0.1 s	10.0 s	Recommended value 0.3s
St.C. (L 18)	STARTING CURRENT	5 A	50 A	MAX A	MAX: Maximum value of welding current Recommended value 30 % or 15 A
		2 %	50 %	200 %	
Sl.u. (L 19)	SLOPE UP	0.0 s	0.0 s	25.0 s	Recommended value 0.1s
- (L 20)	WELDING CURRENT MAXIMUM CURRENT WITH REMOTE CONTROLLER	5 A	80 A	MAX A	MAX: Maximum value of welding current
S.Cu. (L 21)	SECOND CURRENT B-LEVEL	10 %	50 %	200 %	
b.Cu. (L 22)	BASE CURRENT	1 %	40 %	200 %	Recommended value 40 %
PE.t. (L 23)	PEAK TIME / CYCLE TIME	1 %	50 %	99 %	Recommended value 30 % Available with "TYPE OF PULSED=SLOW.
		0.1 s	5.0 s	5.0S	
P.Fr. (L 23 + L 24)	PULSED CURRENT FREQUENCY	0.1 Hz	100 Hz	2.5 kHz	<ul style="list-style-type: none"> Recommended value 1-4Hz for low frequency welding. Recommended value 1kHz with 80% base current and 50% CYCLE for high frequency welding.
bA.t. (L 24)	BASE TIME	0.1 s	5.0 s	5.0 s	Available with "TYPE OF PULSED=SLOW.
Sl.d. (L 25)	DOWN SLOPE	0.0 s	0.0 s	25.0 s	Recommended value 0.5
F.Cu. (L 26)	FINAL CURRENT	5 A	5 A	MAX A	MAX: Maximum value of welding current Recommended value 30 %
		5 %	5 %	80 %	
Po.G. (L 27)	POST GAS TIME	0.0 s	10.0 s	25.0 s	Recommended value 8.0s

For a better understanding of the parameter functions described in the table, refer to the following diagram.

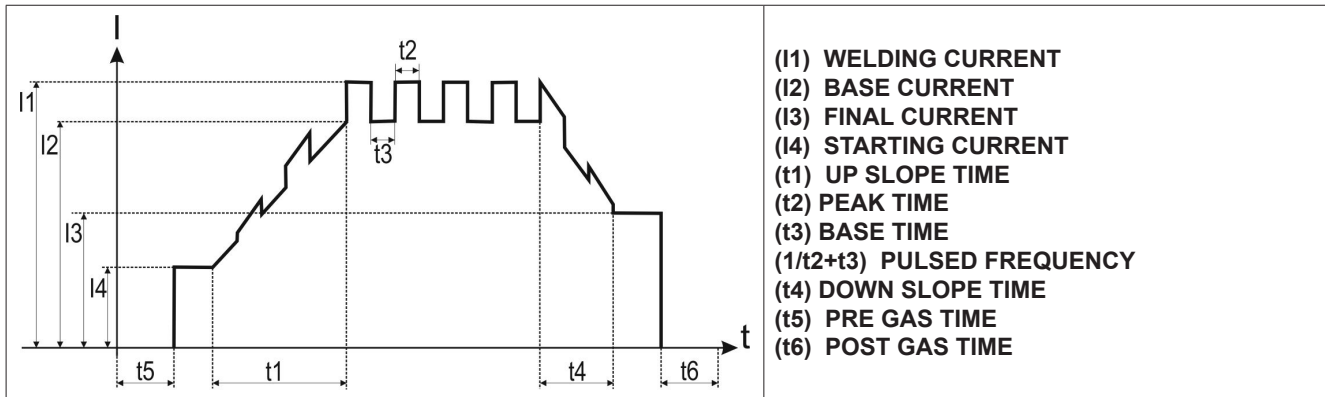

- **The SYNERGIC PULSED TIG DC** enables a highly concentrated arc to be obtained. It is a very stable arc and moves the pool with strong fluctuations. It is ideal for use in spot welding and the creation of thin fillets. It is recommended for thin gauge sheets and in particular where a very stable arc is required (viscous pools)

In this mode, the welding parameters are pulsed: BASE CURRENT; PEAK TIME; PULSED FREQUENCY are only displayed and cannot be modified.

- PRE-GAS TIME

- Time of gas delivery before the arc strike.
- This adjustment is required when fixing points must be created or when welding in hard-to-reach positions that call for the presence of inert atmospheres before striking the arc.
- Consequences of a higher value:
 - This parameter allows a shielded environment to be created, thereby eliminating contaminants at the start of the welding pass.

- STARTING CURRENT

- Unit current output value immediately after the arc strike. The value of this parameter can be set as a percentage of the welding current or as an absolute value expressed in Amperes. The parameter is displayed but it is not used during the welding process when the following setting is present: MULTI TACK = ON The usefulness of having an adjustable initial welding current is that of avoiding welding the part with excessively high current values and thus potentially damaging it. Particularly useful when welding thin sheets.

- SLOPE UP

- Time during which the current changes from the starting value to the welding value by means of a slope.
- This setting is used to avoid damaging the edges of the joint with excessively high current values at the moment of arc striking. The value of the main welding current is increased gradually in order to control the uniformity of material deposition and weld penetration. The parameter is not used during the welding process when the following setting is present: MULTI TACK = ON

- WELDING CURRENT

- This parameter regulates the primary welding current value.

- MAXIMUM CURRENT WITH REMOTE CONTROLLER

- Maximum output current value that can be achieved with remote controller external reference.

- SECOND CURRENT B-LEVEL

- With a rapid press and release (less than 0.5 seconds) of the torch trigger during welding, the output current value switches to the value set by means of the “B-level second current” parameter.
- This function makes it possible to avoid interrupting the welding process when the geometry of the workpiece changes; alternatively, the welding current can be reduced to decrease heating of the part if it becomes too hot during execution of the welding process.
- In DC TIG welding, the parameter is useful when welding different gauge workpieces during the same pass; when moving between different gauges the output current can be changed simply by pressing the torch trigger.

- BASE CURRENT

- Pulsed wave minimum current.
- Consequences of a higher value:
 - Faster creation of weld pool.
 - Increase of heat-affected zone.

- PEAK TIME

- Time for which the current pulse is at the maximum value.
- The SET UP, PULSED TYPE=FAST settings, the adjustment is a % of the PULSED CYCLE (CYCLE TIME=1/PULSED FREQUENCY).
- In the settings for SET UP, PULSED TYPE = SLOW, the adjustment is expressed in seconds.
- Consequences of a higher value:
 - Greater width of the beading and greater welding penetration.
 - Facility to make deeper cuts.
- Consequences of a lower value:
 - Reduction of the bead and of heat-affected zone.
 - Difficult to create a weld pool.

- PULSED CURRENT FREQUENCY

- The greater the frequency, the tighter the bead welding and greater the welding time. Increasing the frequency, restricts the heat affected zone. A high frequency (kHz) pulsed arc is suitable for flat beading (head to head or over head)
- Consequences of a higher value:
 - Slower melt speed.
 - Reduction of heat-affected zone.

- BASE TIME

- Time during which current output is at the base value. Available with settings for SET UP, PULSED TYPE = SLOW, the adjustment is expressed in seconds.
- Consequences of a higher value:
 - The filler material is spread more evenly.
 - Increase of heat-affected zone.

- DOWN SLOPE

- Time during which the current changes from the welding value to the end value by means of a slope. Prevents the formation of craters in the process of turning off the arc. The parameter is not used during the welding process when the following setting is present: MULTI TACK = ON

- FINAL CURRENT

- During electrode welding the parameter makes it possible to obtain a uniform deposit of filler material from the start to the end of the welding process, closing the deposition crater with a current such as to deposit a final droplet of filler material.

ENGLISH

- The value of this parameter can be set as a percentage of the welding current or as an absolute value expressed in Amperes.
- The parameter is displayed but it is not used during the welding process when the following setting is present: MULTI TACK = ON
- By keeping the torch trigger pressed during the 3rd time, the crater filler current is maintained thereby ensuring optimal crater filling, until the post gas time is started by releasing the torch trigger (4th time).

- POST GAS TIME

- Time of post gas delivery when the welding arc is extinguished.
- Consequences of a higher value:
 - More effective pickling (improved appearance of workpiece at the end of the welding pass).
 - Higher gas consumption.
- Consequences of a lower value:
 - Lower gas consumption.
 - Oxidation of electrode tip (more difficult arc strike).

9.2 TIG WELDING - SECOND LEVEL MENU

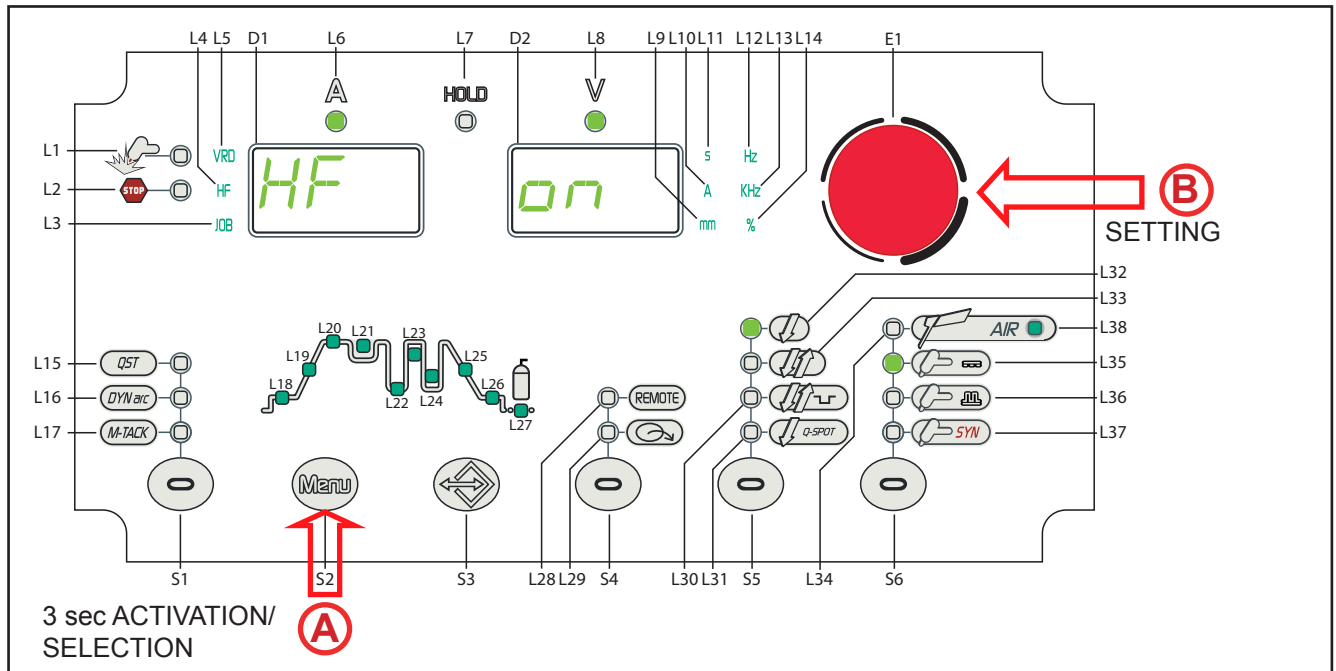

- A**
 - Hold down the **S2** (Menu) button for 3 seconds to access the 2nd level menu.
 - The acronym relative to the setting to be edited appears on the following displays: **D1**.
 - The value relative to the selected setting appears on the following displays: **D2**.
 - Press the **S2** (Menu) button to scroll the list of settings to edit.
- B**
 - Using the **encoder E1**, edit the value of the selected setting. The value is saved automatically.

Press any key (except S2) to save the setting and exit the menu.

Tab. 8 - Parameters of the 2nd level menu: DC TIG mode

ACRONYM	SETTING	MIN	DEFAULT	MAX	NOTES
SP.t.	SPOT TIG TIME	0.01s	0.01s	10.0S	Only with 2 STROKE SPOT
PA.t.	PAUSE TIME	0.01s	oFF	10.0s	Only with 2 STROKE SPOT Only with HF=ON
HF	HF ARC STRIKE ENABLE	oFF	on	on	
SI.u.	MINIMUM PEDAL CURRENT	1 %	5 %	90 %	Only with the PEDAL

Tab. 9 - Parameters of the 2nd level menu: TIG AC mode:

ACRONYM	SETTING	MIN	DEFAULT	MAX	NOTES
SP.t.	SPOT TIG TIME	0.01s	0.01s	10.0S	Only with 2 STROKE SPOT
PA.t.	PAUSE TIME	0.01s	oFF	10.0s	Only with 2 STROKE SPOT Only with HF=ON
HF	HF ARC STRIKE ENABLE	oFF	on	on	
SI.u.	MINIMUM PEDAL CURRENT	1 %	5 %	90 %	Only with the PEDAL

ENGLISH

- SPOT TIG TIME

- Only available with 2 STROKE SPOT When the torch trigger is pressed the welding arc persists for the time set in the parameter. Press the torch trigger again to resume the welding process.
- The result of this is a very precise, non-oxidized welding spot without any plastic deformation of the sheet.

- PAUSE TIME

- Available only with 2 Stroke SPOT and arc strike with HF activated. It causes a pre-set pause time between two spot-welding times. Press the torch trigger to obtain the welding arc for the time set with the parameter SPOT-WELDING TIME. The arc then remains extinguished for the time set by PAUSE TIME and then starts again. This process continues until the torch trigger is released. When the parameter is set to OFF, the operating mode of the Q-SPOT is standard.

- HF ARC START

- This parameter enables the arc strike in the TIG welding procedure by means of a high frequency (HF) current discharge. The high frequency arc strike (HF) prevents the inclusion of impurities at the start of the weld pass. If set to OFF, the ignition will be of a 'LIFT ARC' strip type
 - **HF:** This type of ignition occurs by means of a high-voltage electric discharge but of low amperage (HF) between the electrode tip and the weld workpiece. Once the electric arc is established the generator stops delivering the HF charge. This type of ignition in addition to being very easy and immediate, allows the electrode life to be extended and to keep it very pure allowing the operator to work with a very precise and stable arc.

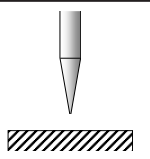
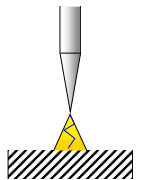
HF ARC IGNITION PROCEDURE		
1		Position the tungsten electrode on the ignition point, so that there is a distance of about 2-3mm between the electrode and the workpiece
2		Press the torch button according to the mode selected. The voltaic arc ignites without touching the weld workpiece.

- **LIFT-ARC:** This type of arc blow is derived from a short low-amperage circuit (to avoid electrode damage) that the operator created between the electrode tip and the workpiece and the consequent rise of the electrode tip that maintains the current flow by creating the so-called electric arc. It is advisable to use LIFT-ARC priming in applications such as maintenance of machinery in operation, welding close to printed circuits or soldering near computers.

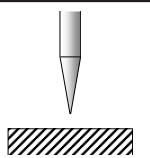
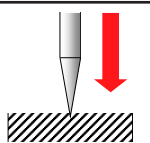
PROCESS FOR ARC IGNITION IN LIFT-ARC MODE:		
1		Position the tungsten electrode on the ignition point, so that there is a distance of about 2-3mm between the electrode and the workpiece.
2		Touch the piece with the electrode and press the torch button according to the mode selected.

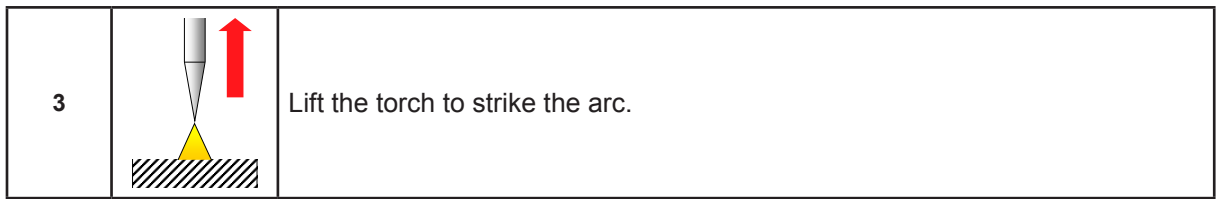

- MINIMUM PEDAL CURRENT

- Minimum output current value with foot pedal controller external reference. The current is set as a percentage with respect to the "maximum foot pedal current" parameter.

9.3 TIG DC WELDING - SPECIAL FUNCTIONS MENU

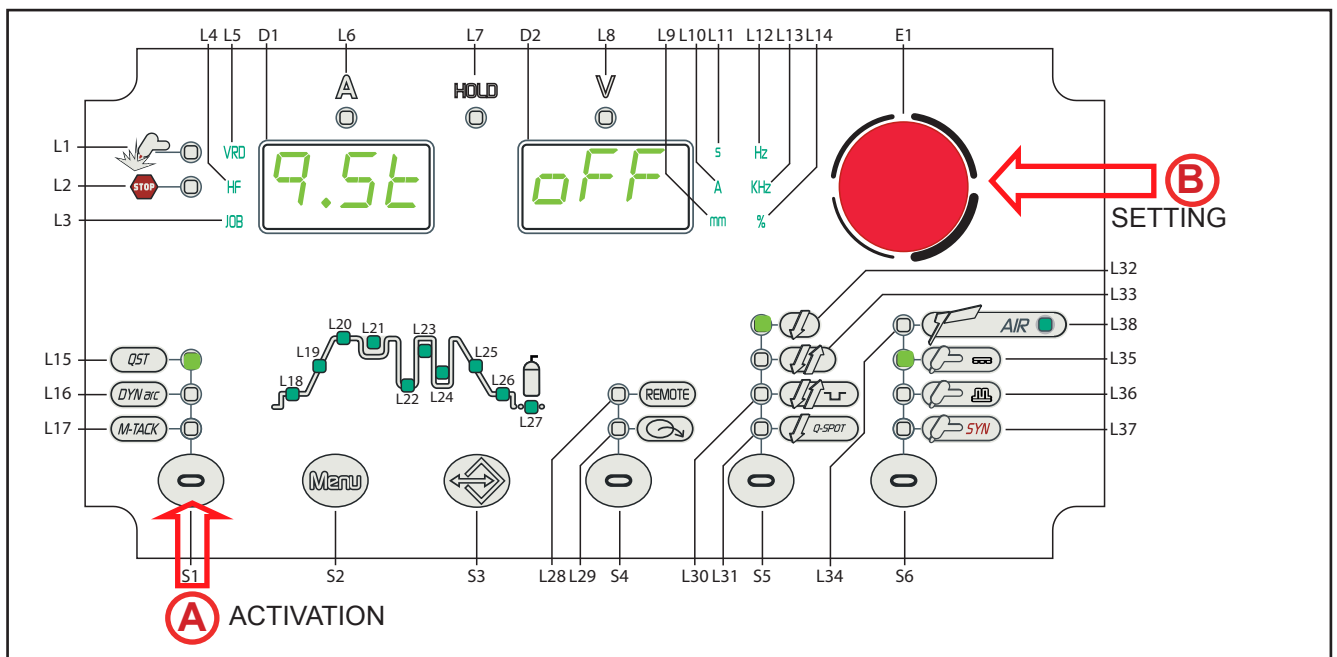

- (A)** Press the **S1** button to activate the special function.
 - The acronym relative to the setting to be edited appears on the following displays: **D1**.
 - The value relative to the selected setting appears on the following displays: **D2**.
- (B)** Using the **encoder E1**, edit the value of the selected setting. The value is saved automatically.

Tab. 11 - Special functions in TIG DC mode

ACRONYM	SETTING	MIN	DEFAULT	MAX	NOTES
q.St.	Q-START	0.1 s	oFF	10.0 s	See Table 12
d.Ar.	DYNAMIC ARC	1	oFF	50	See Table 13 (not with SYNERGIC PULSED TIG)
M.t.A.	MULTI TACK	0.5Hz	oFF	6.0Hz	See Table 14 (not with SYNERGIC PULSED TIG)

Press any key (except S1) to save the setting and quit the menu.

- Q-START

- This parameter allows the unit to start in synergic pulsed TIG mode for the pre-set time interval, before switching automatically to the welding procedure selected on the interface panel. The parameter creates the weld pool more quickly than a standard starting time of the material because

it creates a movement of the two flaps up to speed up the join.

- This parameter is useful when spot welding thin gauge sheet.

Tab. 12 - Recommended Q-START parameters

CORNER/BUTT JOINT		
Sheet thickness (mm)	Current (A)	Q start value (seconds)
1.0mm	35A - 50A	0.5 - 1.0
2.0mm	50A - 80A	
3.0mm	80A - 140A	
4.0mm	140A - 170A	

- DYNAMIC ARC

- This function allows, on the reduction of the arc voltage, an increase of the welding current and vice versa. The size of the DynamicArc variation may be individually adjusted to a value between 1A to 50A. For example, an increase of 50A for 1 volt variation.
- This value must be set depending on the material thickness, and the type of processing to be carried out (values between 1A and 20A for thin layers while a value between 20A and 50A for medium-thick layers).
- Welding power remains constant even when the distance between electrode and workpiece changes.

- Consequences of a higher value:

- The welding arc concentration remains unchanged.
- Prevents electrode sticking.
- Increased welding speed.
- Minor plastic deformity in the welded workpiece.
- Greater penetration at the apex.
- Concentrated heat contribution only to the welding and not to the surrounding area.
- Minor oxidation of the piece and therefore lower post-weld re-work costs.
- Better control of first application in gaps (useful for pipe fitters and installers).
- Ease of welding even for pieces which are not properly prepared.
- Minimization of errors and greater arc stability with motion variations.

STANDARD TIG DC WELDING	TIG DC WELDING WITH DYNAMIC ARC
<p>In varying the length of the arc, the weld pool (D) widens with a consequent increase in the heat contribution of the workpiece, causing it to overheat.</p>	<p>By varying the arc length the weld pool is exactly the same size (D) while avoiding the overheating of the piece, plastic deformations and loss of mechanical characteristics.</p>

Tab. 13 - Recommended DYNAMIC ARC parameters

ANY TYPE OF JOINT		
Sheet thickness (mm)	Current (A)	DnyArc Value (Amperes)
1.0 mm	35A - 50A	5 - 10
2.0 mm	50A - 80A	10 - 15
3.0 mm	80A - 140A	15 - 25
4.0 mm	140A - 170A	25 - 50

In order to have optimum control of the arc, it is advisable to ignite it at a distance of between 4-5mm from the initial point of the joint (point zero) .

- MULTI TACK

- This consists of continual welding that allows optimum control of the thinnest gauge sheets/bevels with irregular shapes.
- Benefits:
 - Major reduction in oxidisation with the absence of deformations.
 - This parameter allows thin gauge sheet to be welded without deformation.
- Consequences of a higher value:
 - Welding of thinner gauge sheet without deformation.
 - Less melting of material, slower welding process.

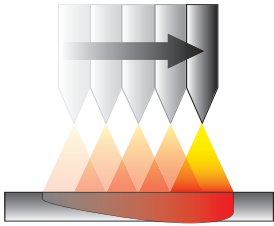
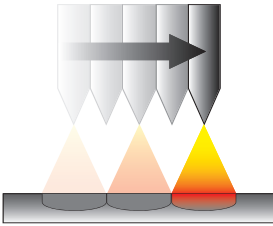
TIG DC WELDING CONTINUOUS	TIG DC WELDING WITH MULTITACK
	
<p>Continuous TIG welding provides continuous energy which prevents the cooling of the piece and does not cause overheating with excessive penetration and excessive distortion effects. Using the pulsed TIG reduces the effect of overheating but it does not solve it completely as the arc will remain on and will still provide energy and heat.</p>	<p>The series of triggers repeated over time allow the piece to disperse the heat between a trigger and another. By adjusting the MultiTack frequency the weld penetration, speed' of execution and in particular the control of the heat input can be optimised as well as any consequent deformation of the piece.</p>
<p>When welding corner joints, the Multitack may be used with excellent results. The welding remains white and free of any oxidation often avoiding the post welding cleanup treatment with acids.</p>	

Tab. 14 - Recommended MULTITACK parameters

CORNER/BUTT JOINT		
Sheet thickness (mm)	Current (A)	Multitack FREQUENCY (Hz)
0.6 mm	40A - 60A	1.0 - 1.5
0.8 mm	60A - 80A	1.0 - 1.5
1.0 mm	80A - 100A	1.0 - 1.5
1.5 mm	90A - 110A	1.0 - 1.5
2.0 mm	110A - 130A	1.0 - 1.5
	130A - 150A	1.5 - 2.0
2.5 mm	150A - 160A	1.0 - 1.5
	160A - 170A	1.5 - 2.0
3.0 mm	170A - 180A	1.0 - 1.5
	180A - 200A	1.5 - 2.0

- It is recommended that a preflow time of between 0.3 - 0.5 seconds be used in order to have optimum protection right from the start, thus avoiding the oxidation of the initial part of the weld. This is also the same for the final part where it is recommended that a post gas time of not less than 3 seconds is used.

10 TORCH TRIGGER PROCEDURE

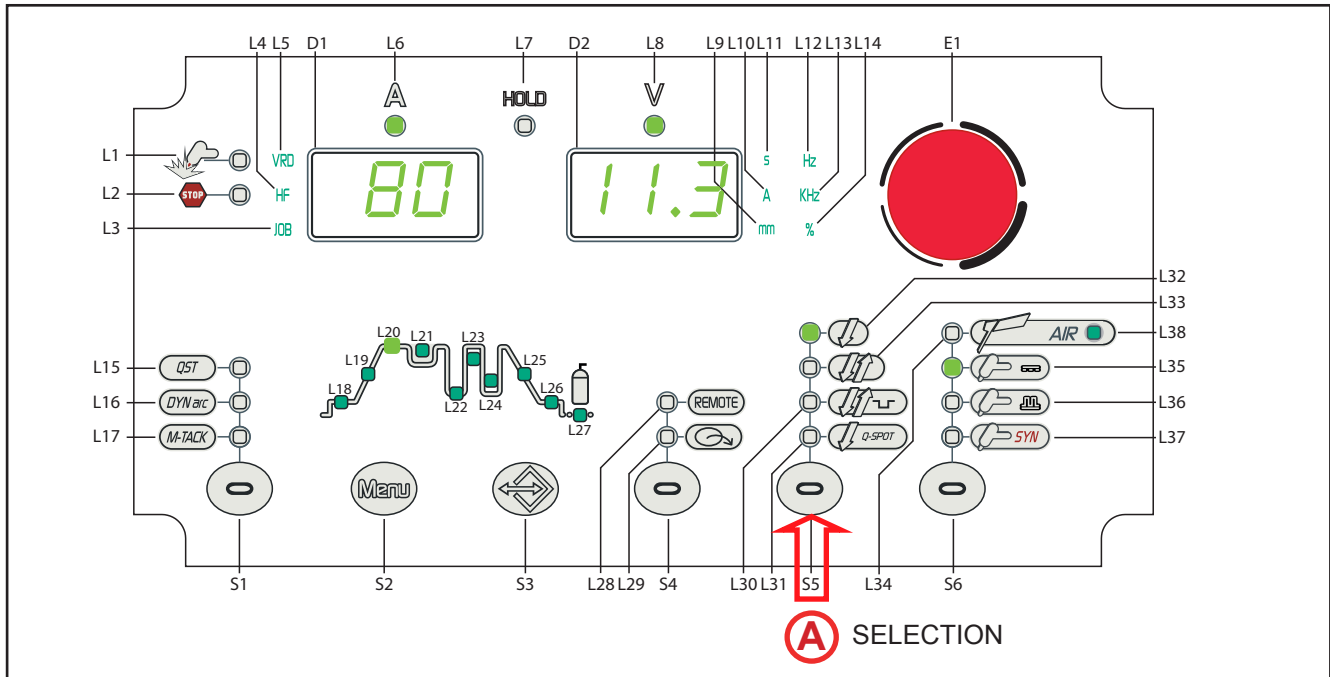

- Press the **S5** button to select the desired PULSED TORCH mode.

A

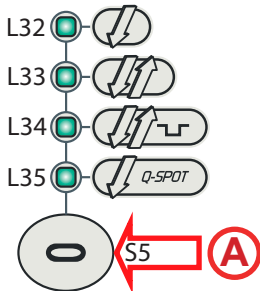

L 32 2 STROKE
L 33 4 STROKE
L 34 4 STROKE BI-LEVEL
L 35 2 STROKE SPOT (Q-SPOT)













Depending on the welding mode selected, specific torch button procedures are available. The availability of certain procedures depends on whether or not certain parameters or functions of the unit are enabled or set in the associated menus. The table shows the settings to be made to enable each procedure.

LEGEND

2T: _____ 2 STROKE LIFT-ARC
2T HF: _____ 2 STROKE WITH HIGH FREQUENCY ARC STRIKE (HF)
4T: _____ 4 STROKE LIFT-ARC
4T HF: _____ 4 STROKE WITH HIGH FREQUENCY ARC STRIKE (HF)

- 4T B-L: _____ 4 STROKE B-LEVEL
 4T B-L HF: _____ 4 STROKE B-LEVEL WITH HIGH FREQUENCY ARC STRIKE (HF)
 2T Q-SPOT: _____ 2 STROKE TACKING
 2T Q-SPOT HF: _____ 2 STROKE TACKING WITH HIGH FREQUENCY ARC STRIKE (HF)
 √: _____ Always available.
 1: _____ Available with the following setting: HF= on

Tab. 16 - Pulsed Torch button mode table.

→ ↓	PROCEDURE							
								
MODE	2T	2T HF	4T	4T HF	4T B-L	4T B-L HF	2T Q-SPOT	2T Q-SPOT HF
 MMA								
 ELECTRODE GOUGING								
 CONTINUOUS DC TIG	√	1	√	1	√	1	√	1
 PULSED MODE DC TIG	√	1	√	1	√	1	√	1
 SYNERGIC PULSED DC TIG	√	1	√	1	√	1	√	1

- 2 STROKE LIFT:

- Touch the workpiece with the torch electrode.
- Press (1T) and keep the torch trigger pressed.
- Slowly lift the torch to strike the arc.
- The welding current reaches the pre-set value, by way of an up slope time, if programmed.
- Release (2T) the trigger to start the weld completion procedure.
- The current reaches the end current value in the time set in the down slope time parameter.
- The arc is extinguished.
- Gas delivery continues for the time set in the post gas parameter.

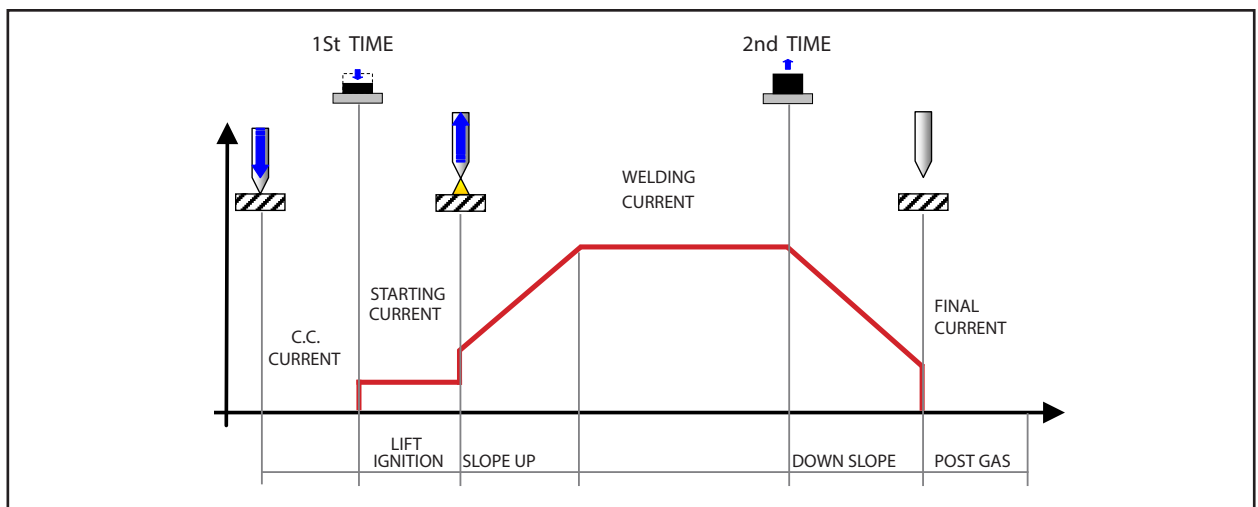

ENGLISH

- 2 STROKE + HF

- Bring the torch up to the work until the electrode tip is approximately 2 or 3 mm away.
- Press (1T) and keep the torch trigger pressed.
- The arc strikes without contact with the workpiece and the voltage discharges (HF) cease automatically.
- The welding current reaches the pre-set value, by way of an up slope time, if programmed.
- Release (2T) the trigger to start the weld completion procedure.
- The current reaches the end current value in the time set in the down slope time parameter.
- The arc is extinguished.
- Gas delivery continues for the time set in the post gas parameter.

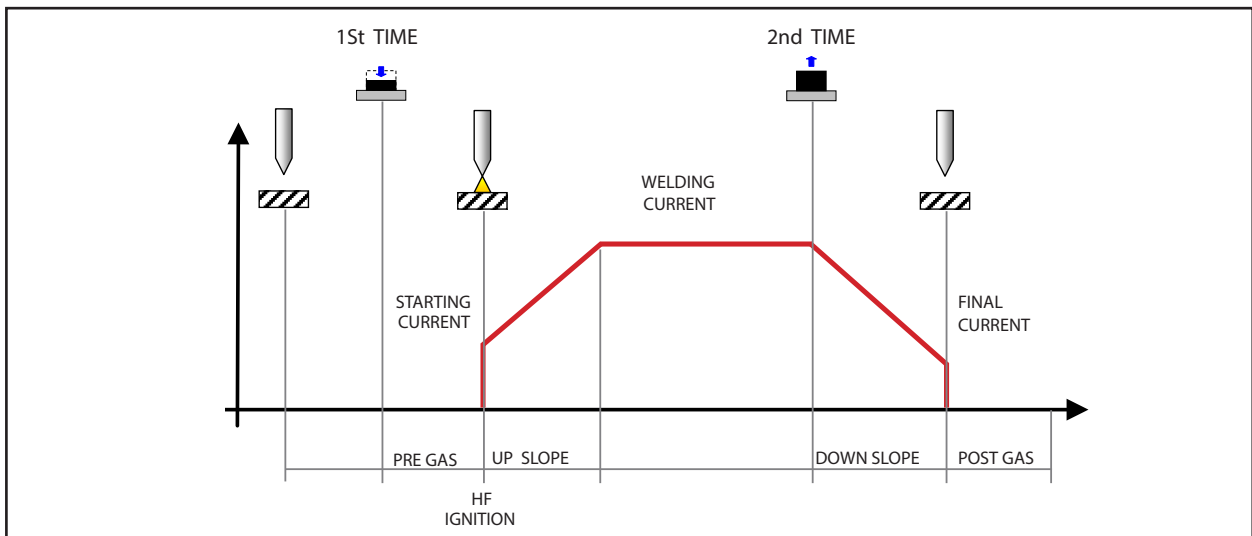

- 4 STROKE LIFT:

- Touch the workpiece with the torch electrode.
- Press (1T) and keep the torch trigger pressed.
- Slowly lift the torch to strike the arc.
- The arc strikes, the welding current assumes the pilot current value. (if activated from the SET UP menu.)
- Release (2T) the torch trigger.
- The welding current reaches the pre-set value, by way of an up slope time, if programmed.
- Press (3T) the trigger and keep it pressed to start the weld completion procedure.
- The current reaches the end current value in the time set in the down slope time parameter.
- The arc continues and the current output will be the value set in the end current parameter.
- In these conditions the weld pool can be closed (crater filler current).
- Release (4T) the trigger to extinguish the arc.
- Gas delivery continues for the time set in the post gas parameter.

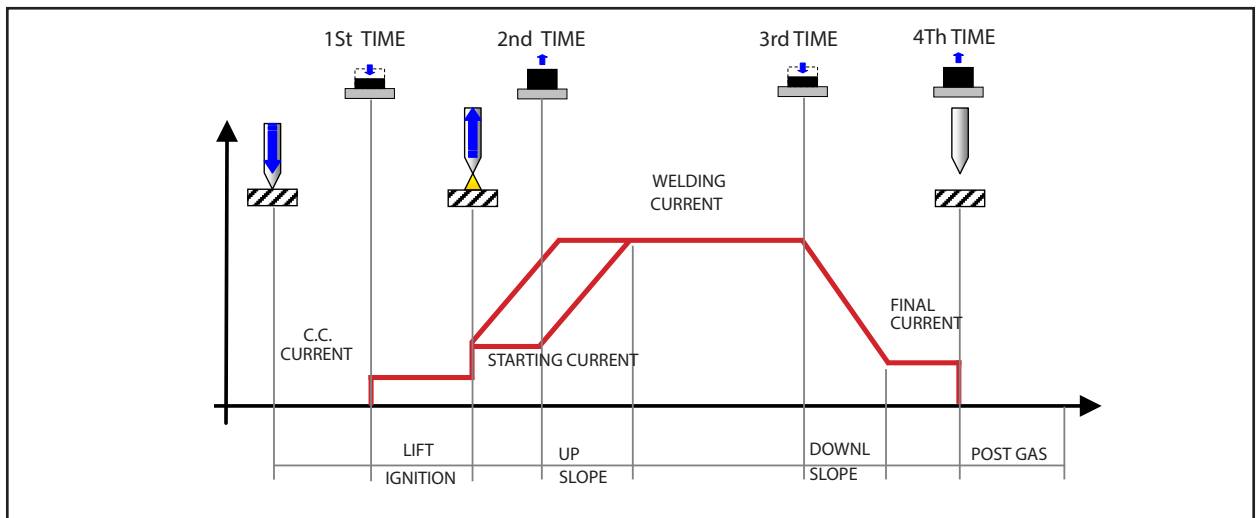

- 4 STROKE + HF

- Bring the torch up to the work until the electrode tip is approximately 2 or 3 mm away.
- Press (1T) and keep the torch trigger pressed.
- The arc strikes without contact with the part and the voltage discharges (HF) cease automatically, the welding current will assume the pilot current value. (if activated from the SET UP menu.)
- Release (2T) the torch trigger.
- The welding current reaches the pre-set value, by way of an up slope time, if programmed.
- Press (3T) the trigger and keep it pressed to start the weld completion procedure.
- The current reaches the end current value in the time set in the down slope time parameter.
- The arc continues and the current output will be the value set in the end current parameter.
- In these conditions the weld pool can be closed (crater filler current).
- Release (4T) the trigger to extinguish the arc.
- Gas delivery continues for the time set in the post gas parameter.

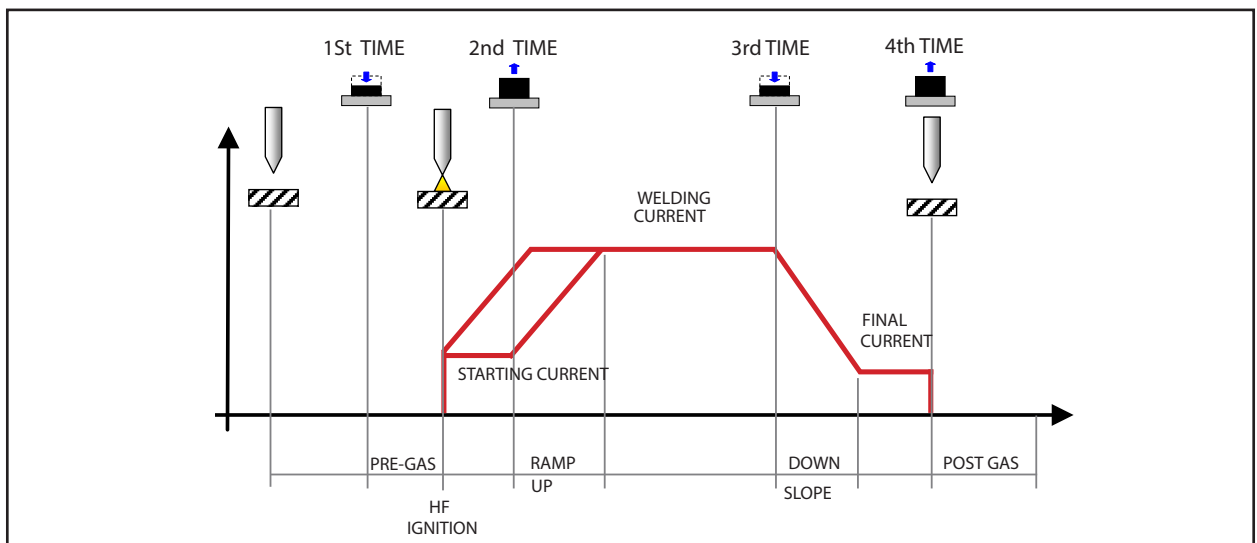

ENGLISH

4 STROKE B-LEVEL LIFT:

- Touch the workpiece with the torch electrode.
- Press (1T) and keep the torch trigger pressed.
- Slowly lift the torch to strike the arc.
- The arc strikes, the welding current assumes the pilot current value. (if activated from the SET UP menu.)
- Release (2T) the torch trigger.
- The welding current reaches the pre-set value, by way of an up slope time, if programmed.
- Press and immediately release the torch trigger to switch to the second welding current.
- The trigger must not be pressed for more than 0.3 seconds; otherwise, the weld completion stage will start.
- When the trigger is pressed and released immediately, the system returns to the welding current.
- Press (3T) the trigger and keep it pressed to start the weld completion procedure.
- The current reaches the end current value in the time set in the down slope time parameter.
- The arc continues and the current output will be the value set in the end current parameter.
- In these conditions the weld pool can be closed (crater filler current).
- Release (4T) the trigger to extinguish the arc.
- Gas delivery continues for the time set in the post gas parameter.

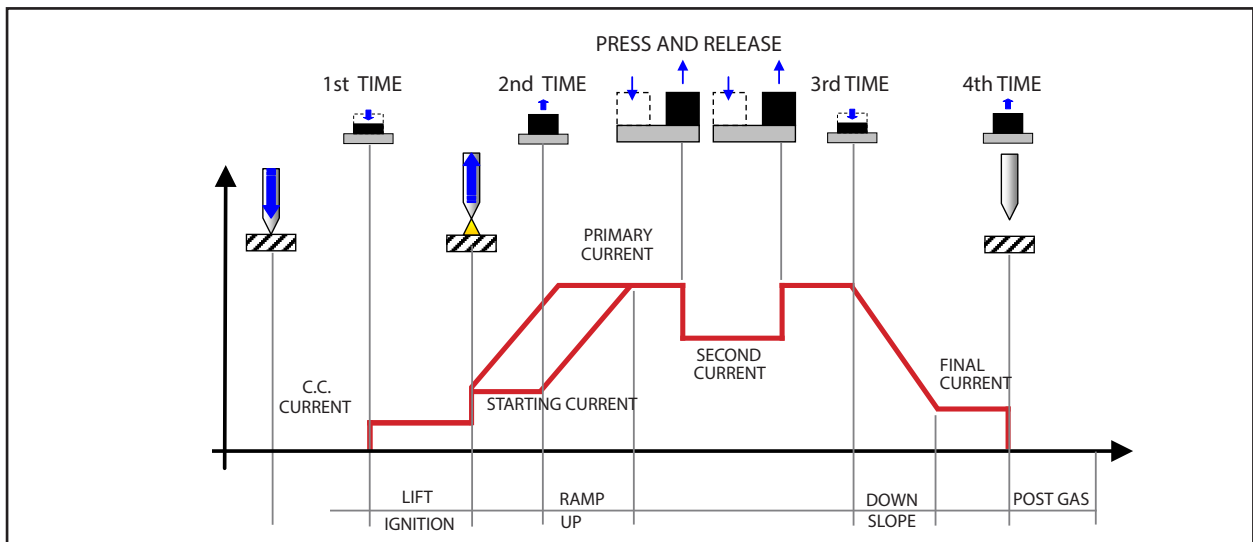

- 4 STROKE B-LEVEL:

- Bring the torch up to the work until the electrode tip is approximately 2 or 3 mm away.
- Press (1T) and keep the torch trigger pressed.
- The arc strikes without contact with the part and the voltage discharges (HF) cease automatically, the welding current will assume the pilot current value. (if activated from the SET UP menu.)
- Release (2T) the torch trigger.
- The arc strikes without contact with the workpiece and the voltage discharges (HF) cease automatically.
- The welding current reaches the pre-set value, by way of an up slope time, if programmed.
- Press and immediately release the torch trigger to switch to the second welding current.
- The trigger must not be pressed for more than 0.3 seconds; otherwise, the weld completion stage will start.
- When the trigger is pressed and released immediately, the system returns to the welding current.
- Press (3T) the trigger and keep it pressed to start the weld completion procedure.
- The current reaches the end current value in the time set in the down slope time parameter.
- The arc continues and the current output will be the value set in the end current parameter.
- In these conditions the weld pool can be closed (crater filler current).

- Release (4T) the trigger to extinguish the arc.
- Gas delivery continues for the time set in the post gas parameter.

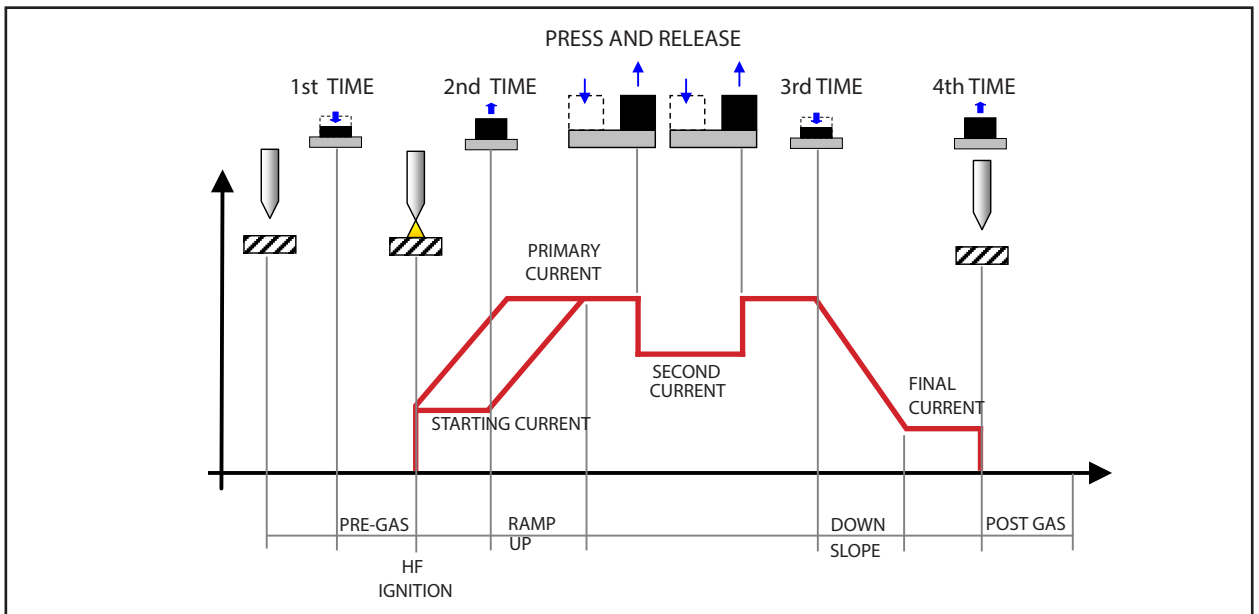

10.1 2 STROKE SPOT - Q-SPOT FUNCTION

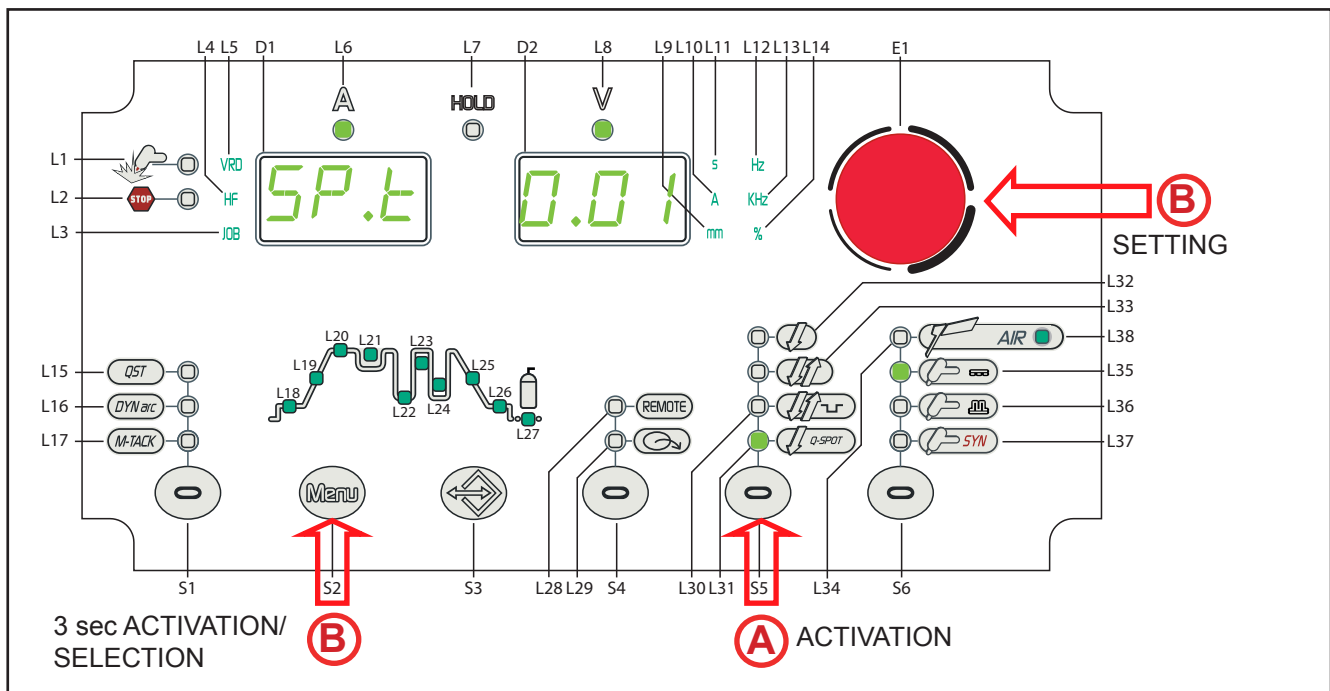

- (A)** ○ Press the **S5** button to select the PULSED TORCH 2 STROKE SPOT mode.
- (B)** ○ Hold down the **S2** button for 3 seconds to access the 2nd level menu.
 - The acronym relative to the setting to be edited appears on the following displays: **D1**.
 - The value relative to the selected setting appears on the following displays: **D2**.
- Press the **S2** button to scroll the list of settings to edit. Select SP.t. SPOT-WELDING TIME
- (C)** ○ Using the **encoder E1** , edit the value of the selected setting. The value is saved automatically.

Press any key (except **S2**) to save the setting and exit the menu.

Tab. 17 - Parameters of the 2nd level menu: 2 STROKE SPOT mode

ACRONYM	SETTING	MIN	DEFAULT	MAX	NOTES
SP.t.	SPOT TIG TIME	0.01s	0.01s	10.0S	Only with 2 STROKE SPOT
PA.t.	PAUSE TIME	0.01s	oFF	10.0s	Only with 2 STROKE SPOT Only with HF=ON

- Q-SPOT

- This function, only present in 2 STROKE SPOT, facilitates spot-welding:
 - It allows the exact positioning of the electrode at the point to be joined. The electrode is conveniently placed at the desired location.
 - Only after lifting of the electrode, the machine emits pulse welding for the stipulated time.
 - It considerably reduces the risk of contamination of the joint with the electrode.
 - While pressing the torch button, the process may be repeated as many times as required.

- This function is ideally suited to the welding of thinner gauges, head to head position and the pipes. Place the torch with the electrode on the precise point to be fixed.
 - Press the torch trigger and then lift.
 - After lifting the torch, a precise trigger will follow.
- **Recommended:** Set the highest current possible with the lowest possible time. Value: 0.01-0.5 Sec.
- **Warning:** It is important to check the up and down slopes are null (0sec.). If the spot-welding time is less than 1.0s, the up and down slopes are eliminated automatically by the welding process, although they are displayed and can be set by the user interface.
- The Q-Spot function has a dual mode, i.e. it is possible to carry out spot welding without contact with the piece.
 - It is recommended that the spot-welding position is researched (an electrode that contacts the workpiece) for thin layers (less than 1.5mm) while for greater thicknesses, without making contact with the workpiece.

- 2 STROKE SPOT LIFT:

- Touch the workpiece with the torch electrode.
- Press (1T) and keep the torch trigger pressed.
- Slowly lift the torch to strike the arc.
- Release (2T) the torch trigger.
- The welding current reaches the pre-set value, by way of an up slope time, if programmed.
- The welding procedure continues, at the pre-set current, for the time set with the spot time parameter.
- The current reaches the end current value in the time set in the down slope time parameter.
- The arc is extinguished.
- Gas delivery continues for the time set in the post gas parameter.

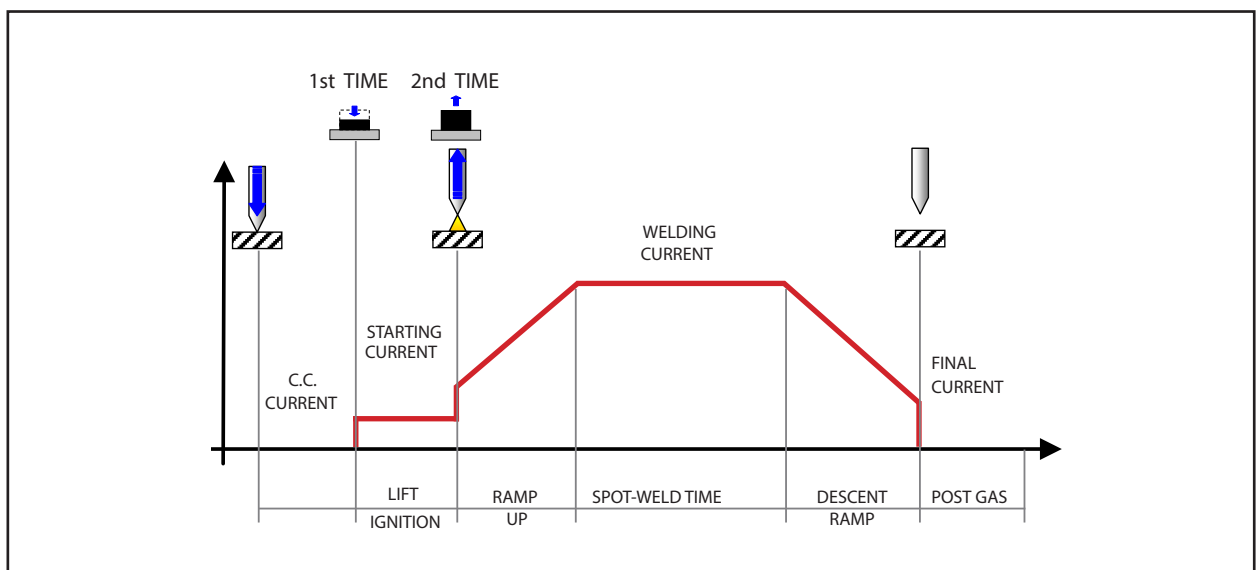

ENGLISH

- 2 STROKE SPOT HF:

- Bring the torch up to the work until the electrode tip is approximately 2 or 3 mm away.
- Press (1T) the torch trigger.
- The arc strikes without contact with the workpiece and the voltage discharges (HF) cease automatically.
- Release (2T) the torch trigger.
- The welding current reaches the pre-set value, by way of an up slope time, if programmed.
- The welding procedure continues, at the pre-set current, for the time set with the spot time parameter.
- The current reaches the end current value in the time set in the down slope time parameter.
- The arc is extinguished.
- Gas delivery continues for the time set in the post gas parameter.

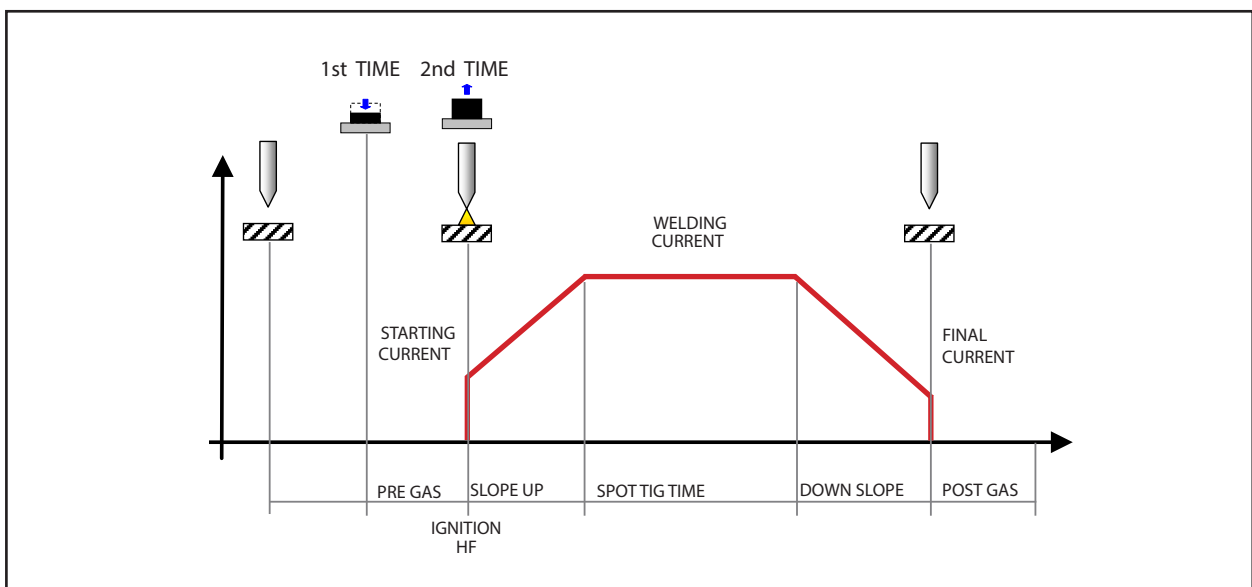

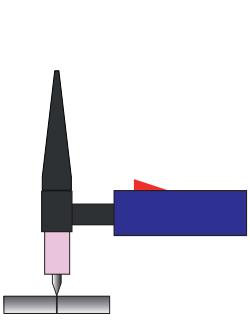
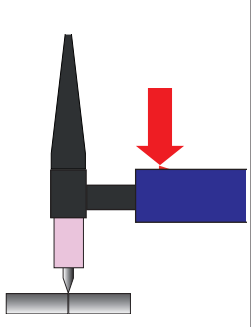
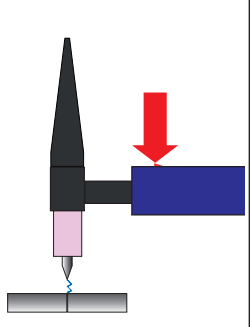
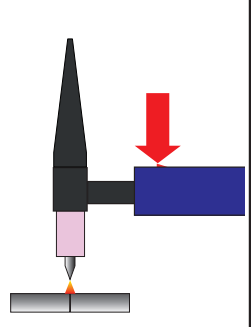
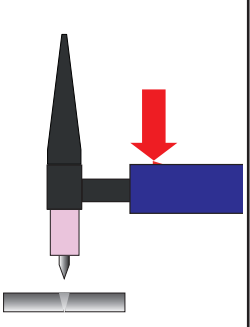
				
1. Position the torch with the electrode on the workpiece.	2. Press the torch trigger and keep it pressed.	3. Lift the torch slightly. As soon as the electrode is lifted then the HF ignition starts.	4. The arc ignites for A few hundredths of a second (time can be set up).	5. The result of this is a very precise, not oxidized welding spot without any plastic deformation of the sheet.

PROCEDURE WITH CONTINUOUS PRESSURE OF TORCH BUTTON

- Bring the torch up to the work until the electrode tip is approximately 2 or 3 mm away.
- Press (1T) the torch trigger.
- The arc strikes without contact with the workpiece and the voltage discharges (HF) cease automatically.
- The welding current reaches the pre-set value, by way of an up slope time, if programmed.
- The welding procedure continues, at the pre-set current, for the time set with the spot time parameter.
- The current reaches the end current value in the time set in the down slope time parameter.
- The arc is extinguished.
- Gas delivery continues for the time set in the post gas parameter.
- Touch the workpiece with the torch electrode.
- Slowly lift the torch to strike the arc.

The welding parameters are available in accordance with the selected welding mode and procedure. Certain parameters are available only after other parameters or functions of the unit have been enabled or set.

The table shows the settings required to enable each parameter.

LEGEND

















- √: ___ Always available.
- 1: ___ Available with the following setting: MULTI TACK = OFF
- 2: ___ Available when remote control is enabled and a remote control pedal is connected to the unit.
- 3: ___ Available with the following setting: HF ARC START = ON
- 4: ___ Available when foot pedal controller is disabled.
- 5: ___ Available with the following setting: TYPE OF PULSED CURRENT = SLO.
- 6: ___ Available with the following setting: TYPE OF PULSED CURRENT = FA.

Meaning of symbols

1+2 = All conditions must be fulfilled (both 1 and 2).

ENGLISH

Tab. 18 - Table showing enabled Welding Parameters

MENU ↓	MODE →															
	PROCEDURE →															
	PARAMETER ↓															
1°	WELDING CURRENT	√	√	√	√	√	√	√	√	√	√	√	√	√	√	√
1°	HOT-START	√														
1°	ARC-FORCE	√														
1°	PRE-GAS TIME PRE-GAS			3	3	3	3	3	3	3	3	3	3	3	3	3
1°	STARTING CURRENT			√	√	√	√	√	√	√	√	√	√	√	√	√
1°	UP SLOPE			√	√	√	√	√	√	√	√	√	√	√	√	√
1°	SECOND CURRENT B-LEVEL					√				√				√		
1°	STARTING CURRENT							√	√	√	√	√	√	√	√	√
1°	PEAK TIME							√	√	√	√	√	√	√	√	√
1°	PULSED CURRENT FREQUENCY							6	6	6	6	6	6	6	6	6
1°	BASE TIME							5	5	5	5					
1°	DOWN SLOPE			√	√	√	√	√	√	√	√	√	√	√	√	√
1°	END CURRENT			√	√	√	√	√	√	√	√	√	√	√	√	√
1°	POST GAS TIME			√	√	√	√	√	√	√	√	√	√	√	√	√
2°	TYPE OF ELECTRODE	√														
2nd	VRD	√	√													
2°	LONG ARC VOLT-AGE	√														
2nd	SPOT-WELDING TIME						√				√					√
2nd	HF ARC START			√	√	√	√	√	√	√	√	√	√	√	√	√
2ND	MINIMUM PEDAL CURRENT			2			2	2			2	2				2
2°	AC WAVEFORM															
SPECIAL	Q-START			3+1	3+1	3+1		3+1	3+1	3+1						
SPECIAL	DYNAMIC ARC			4+1	1			3+1	1							
SPECIAL	MULTI TACK			3	3			3	3			3	3			

11 JOBS MANAGEMENT

Personalised welding settings, or JOBS, can be saved in memory locations and subsequently uploaded. Up to 50 JOBS can be saved (j01-j50).

JOBS can be managed only when the unit is not in welding mode.

The SETUP menu settings cannot be saved by means of the JOBS.

When a JOB is loaded and an UP/DOWN torch is installed, press the torch triggers to select the saved JOBS.

If there are no JOBS loaded, the UP/DOWN buttons on the torch serve to adjust the welding current.

11.1 SAVING A JOB

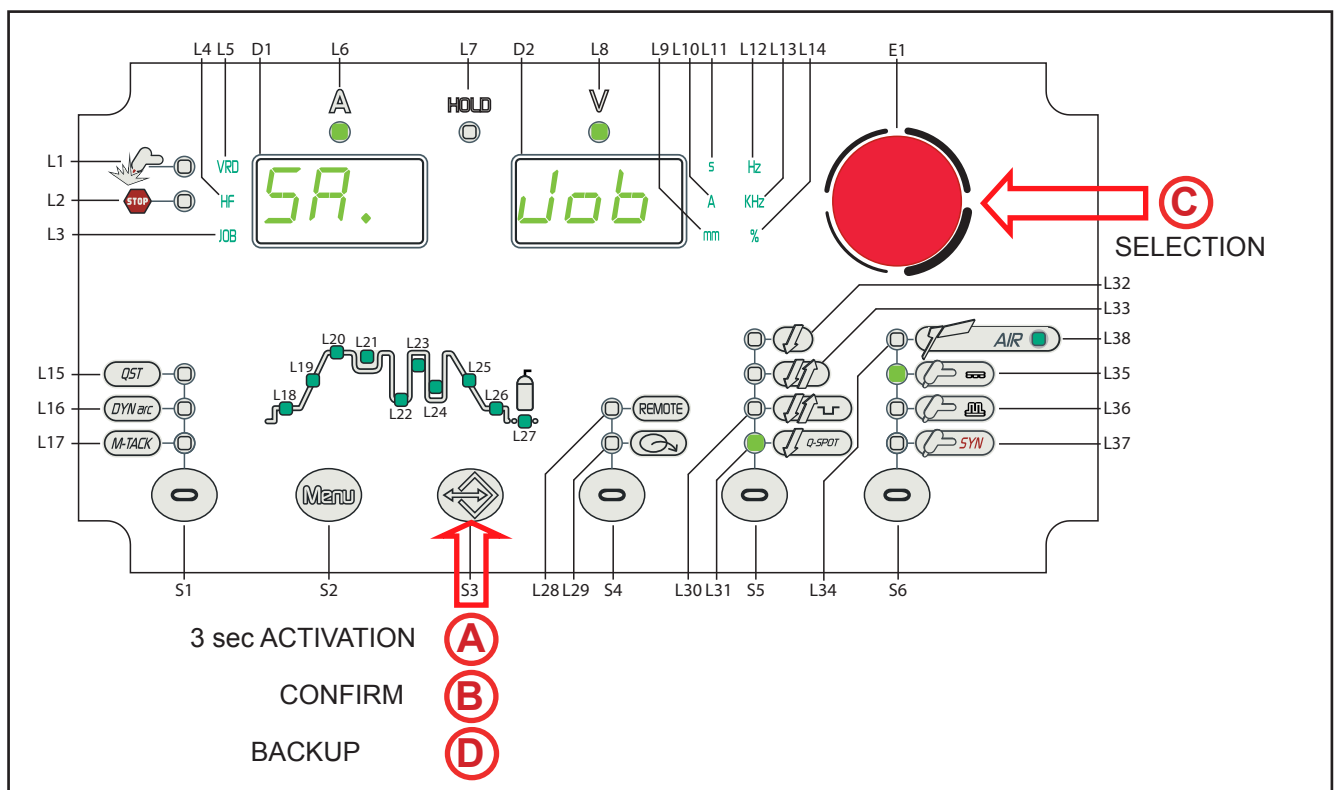

- A** ○ Hold down the **S3** button for 3 seconds to gain access to the JOB save/delete menu.
 - **SA. Job** : The message appears on the following displays: **D1-D2.**
- B** ○ Press the **S3** button to confirm.
 - **SA. J.xx** : The message appears on the following displays: **D1-D2.**
 - xx= number of the first free job.
- C** ○ Using the **encoder E1**, select the desired job number. On selecting a currently occupied memory location, the job number flashes.
- D** ○ Press the **S3** button to save the JOB and exit the menu. If you confirm at this point, the new job will overwrite the previously saved settings.

Press any button (except S3) to exit without confirming.

11.2 DELETING A JOB

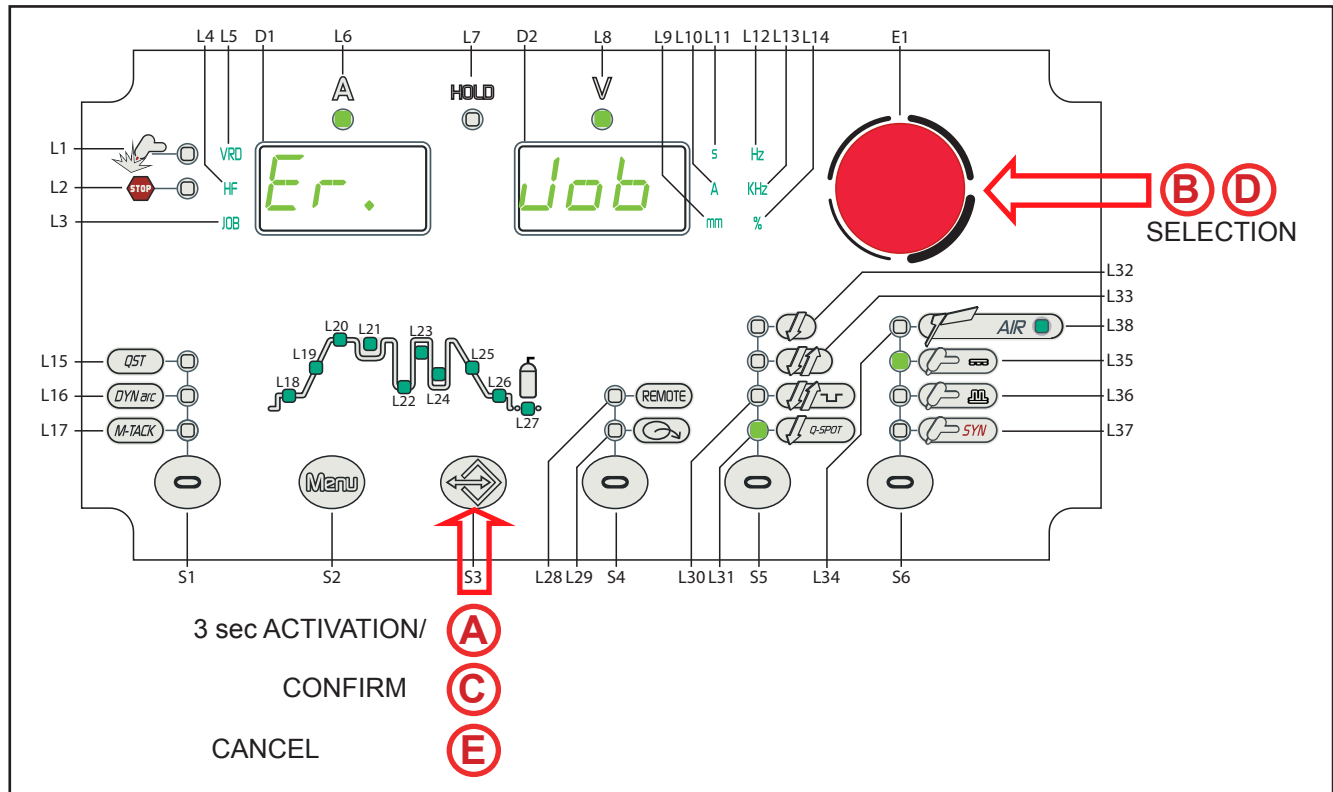

- (A)** ○ Hold down the **S3** button for 3 seconds to gain access to the JOB save/delete menu.
 - **SA. Job** : The message appears on the following displays: **D1-D2**.
- (B)** ○ Use the **encoder E1** , to select the following setting: **Er. Job**.
 - The message appears only if there are saved JOBS, on the following displays: **D1-D2**.
- (C)** ○ Press the **S3** button to confirm.
 - **Er. J.xx** : The message appears on the following displays: D1-D2.
 - xx= number of the last job used.
- (D)** ○ Use the **encoder E1** , to select the number of the job to be deleted.
- (E)** ○ Press the **S3** button to cancel the JOB and quit the menu.

Press any button (except **S3**) to exit without confirming.

11.3 LOADING A JOB

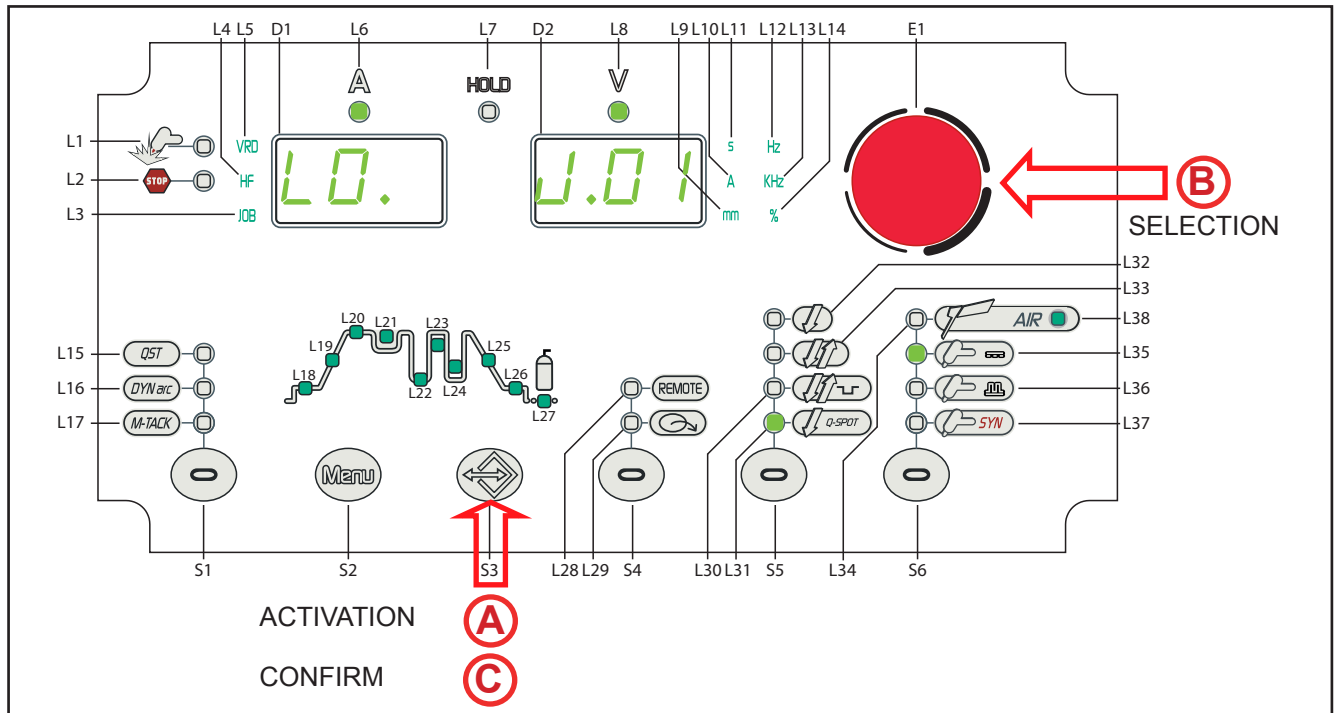

- (A)** ○ Press the **S3** button to activate the LOAD JOB menu.

 - **LO. JXX** : Only when the jobs have been uploaded, the message is shown on the following displays: **D1-D2**.
 - xx= number of the last job used.
 - **No. Job** : If there are no jobs in the memory the message is shown on the following displays: **D1-D2**.
- (B)** ○ Using the **encoder E1** , select the job number to be loaded.
- (C)** ○ Press the **S3** button to load the JOB and exit from the menu.

 - **J.xx** : The message appears for a few seconds on the following displays: **D1**.
 - **JOB** The LED illuminates.

To quit the currently loaded JOB, change any setting on the power source user interface. Press any button (except **S3**) to exit without confirming.

11.4 SELECTING JOBS USING THE TORCH BUTTONS





When an UP/DOWN torch is installed you can select the JOBS in a JOB sequence using the buttons on the welding torch. To create the JOBS sequence, leave a free memory slot before and after the group of JOBS to be included in the sequence.

Sequence 1			JOB not saved	Sequence 2			JOB not saved	Sequence 3		
J.01	J.02	J.03		J.05	J.06	J.07		J.09	J.10	J.11



Select and upload one of the JOBS in the required sequence (e.g. J.06) on the power source user interface.

Use the torch buttons to scroll the JOBS of sequence 2 (J.05, J.06, J.07).

12 TECHNICAL DATA



Directives applied	Waste electrical and electronic equipment (WEEE)
	Electromagnetic compatibility (EMC)
	Low voltage (LVD)
	Restriction of the use of certain hazardous substances (RoHS)
Construction standards	EN 60974-1; EN 60974-3; EN 60974-10 Class A
Conformity markings	 Equipment compliant with European directives in force
	 Equipment suitable in an environment with increased hazard of electric shock
	 Equipment compliant with WEEE directive
	 Equipment compliant with RoHS directive

12.1 CRUISER 322T – POWER PULSE 322T



Supply voltage	3 x 400 Va.c. ± 15 % / 50-60 Hz			
Mains protection	25 A 500 V Delayed			
Zmax	This equipment complies with IEC 61000-3-12 provided that the maximum permissible system impedance is less than or equal to 27 mΩ at the interface point between the user's supply and the public system. It is the responsibility of the installer or user of the equipment to ensure, by consultation with the distribution network operator if necessary, that the equipment is connected only to a supply with maximum permissible system impedance less than or equal to 27 mΩ.			
Dimensions (L x D x H)	690 x 290 x 450 mm			
Weight	45.0 kg			
Insulation class	H			
Protection rating	IP23			
Cooling	AF: Air-over cooling (fan assisted)			
Maximum gas pressure	0,5 MPa (5 bar)			
Static characteristic	MMA	 Falling characteristic		
	TIG	 Falling characteristic		
	MIG/MAG	 Flat characteristic		
Welding mode		MMA	TIG	MIG/MAG
Current and voltage adjustment range		10 A / 20.4 V 300 A - 32.0 V	5 A / 10.2 V 320 A - 22.8 V	10 A / 14.5 V 320 A / 30.0 V
Welding current / Working voltage	40% (40° C)	--	--	--
	60% (40° C)	300 A - 32.0 V	320 A - 22.8 V	320 A / 30.0 V
	100% (40° C)	250 A - 30.0 V	260 A - 20.4 V	260 A / 27.0 V
Maximum input power	40% (40° C)	--	--	--
	60% (40° C)	14.3 kVA – 11.0 kW	11.6 kVA – 8.5 kW	15.2 kVA – 11.6 kW
	100 % (40° C)	11.4 kVA – 8.7 kW	8.8 kVA – 6.4 kW	11.6 kVA – 8.5 kW
Maximum supply current	40% (40° C)	--	--	--
	60% (40° C)	20.9 A	16.6 A	22.0 A
	100 % (40° C)	16.7 A	12.7 A	16.5 A
Maximum Effective Supply Current	40% (40° C)	--	--	--
	60% (40° C)	16.2A	12.8 A	17.0 A
	100 % (40° C)	16.7 A	12.7 A	16.5 A

No-load voltage (U ₀)		73 V
Reduced no-load voltage (U _r)		10 V
Rated HF peak voltage (U _p)		10.8 kV
Arc striking device designed to work with manual guided torch.		

12.2 CRUISER 402T – POWER PULSE 402T

Supply voltage	3 x 400 Va.c. ± 15 % / 50-60 Hz			
Mains protection	32 A 500 V Delayed			
Z _{max}	This equipment complies with IEC 61000-3-12 provided that the maximum permissible system impedance is less than or equal to 27 mΩ at the interface point between the user's supply and the public system. It is the responsibility of the installer or user of the equipment to ensure, by consultation with the distribution network operator if necessary, that the equipment is connected only to a supply with maximum permissible system impedance less than or equal to 27 mΩ.			
Dimensions (L x D x H)	690 x 290 x 450 mm			
Weight	54.0 kg			
Insulation class	H			
Protection rating	IP23			
Cooling	AF: Air-over cooling (fan assisted)			
Maximum gas pressure	0,5 MPa (5 bar)			
Static characteristic	MMA	 Falling characteristic		
	TIG	 Falling characteristic		
	MIG/MAG	 Flat characteristic		
Welding mode		MMA	TIG	MIG/MAG
Current and voltage adjustment range		5 A / 20.2 V 400 A / 36.0 V	5 A / 10.2 V 400 A / 26.0 V	20 A / 15.0 V 400 A / 34.0 V
Welding current / Working voltage	50% (40° C)	--	--	--
	60% (40° C)	--	--	--
	100% (40° C)	400 A / 36.0 V	400 A / 26.0 V	400 A / 34.0 V
Maximum input power	50% (40° C)	--	--	--
	60% (40° C)	--	--	--
	100 % (40° C)	18.1 kVA – 15.9 kW	13.0 kVA – 11.4 kW	17.5 kVA – 15.3 kW
Maximum supply current	50% (40° C)	--	--	--
	60% (40° C)	--	--	--
	100 % (40° C)	25.5 A	18.4 A	24.3 A
Maximum Effective Supply Current	50% (40° C)	--	--	--
	60% (40° C)	--	--	--
	100 % (40° C)	25.5 A	18.4 A	24.3 A
No-load voltage (U ₀)		83V		
Reduced no-load voltage (U _r)		9V		
Rated HF peak voltage (U _p)		10.8 kV		
Arc striking device designed to work with manual guided torch.				

12.3 CRUISER 502T – POWER PULSE 502T

Supply voltage	3 x 400 Va.c. ± 15 % / 50-60 Hz			
Mains protection	40 A 500 V Delayed			
Zmax	This equipment complies with IEC 61000-3-12 provided that the maximum permissible system impedance is less than or equal to 49 mΩ at the interface point between the user's supply and the public system. It is the responsibility of the installer or user of the equipment to ensure, by consultation with the distribution network operator if necessary, that the equipment is connected only to a supply with maximum permissible system impedance less than or equal to 49 mΩ.			
Dimensions (L x D x H)	690 x 290 x 450 mm			
Weight	54.0 kg			
Insulation class	H			
Protection rating	IP23			
Cooling	AF: Air-over cooling (fan assisted)			
Maximum gas pressure	0.5 MPa (5 bar)			
Static characteristic	MMA	 Falling characteristic		
	TIG	 Falling characteristic		
	MIG/MAG	 Flat characteristic		
Welding mode		MMA	TIG	MIG/MAG
Current and voltage adjustment range		10 A / 20.4 V 500 A / 40.0 V	5 A / 10.2 V 500 A / 30.0 V	20 A / 15.0 V 500 A / 39.0 V
Welding current / Working voltage	30% (40° C)	500 A / 40.0 V	500 A / 30.0 V	500 A / 39.0 V
	60% (40° C)	450 A / 38.0 V	460 A / 28.4 V	450 A / 36.5 V
	100% (40° C)	400 A / 36.0 V	400 A / 26.0 V	400 A / 34.0 V
Maximum input power	30% (40° C)	24.3 kVA – 22.2 kW	18.2 kVA – 16.6 kW	23.7 kVA – 21.7 kW
	60% (40° C)	21.2 kVA – 19.0 kW	16.1 kVA – 14.5 kW	20.3 kVA – 18.3 kW
	100 % (40° C)	18.1 kVA – 15.9 kW	13.0 kVA – 11.4 kW	17.5 kVA – 15.3 kW
Maximum supply current	30% (40° C)	35.1 A	26.3 A	34.3 A
	60% (40° C)	30.0 A	22.8 A	28.5 A
	100 % (40° C)	25.5 A	18.4 A	24.3 A
Maximum Effective Supply Current	30% (40° C)	24.8 A	18.6 A	24.2 A
	60% (40° C)	23.2 A	17.7 A	22.1 A
	100 % (40° C)	25.5 A	18.4 A	24.3 A
No-load voltage (U0)	83V			
Reduced no-load voltage (Ur)	9V			
Rated HF peak voltage (Up)	10.8 kV Arc striking device designed to work with manual guided torch.			

13 ELECTRICAL DIAGRAM

13.1 CRUISER 322T - POWER PULSE 322T

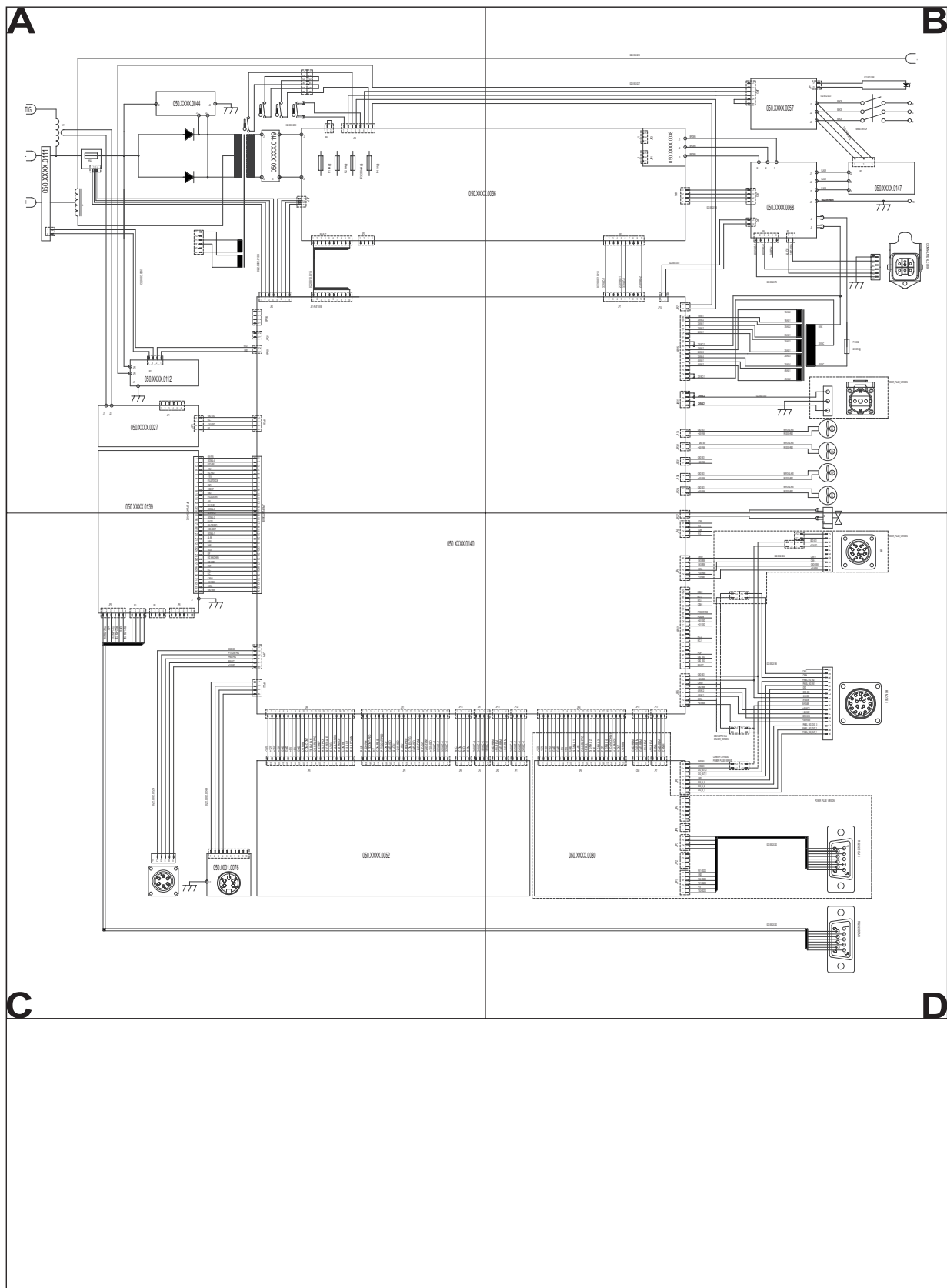

A

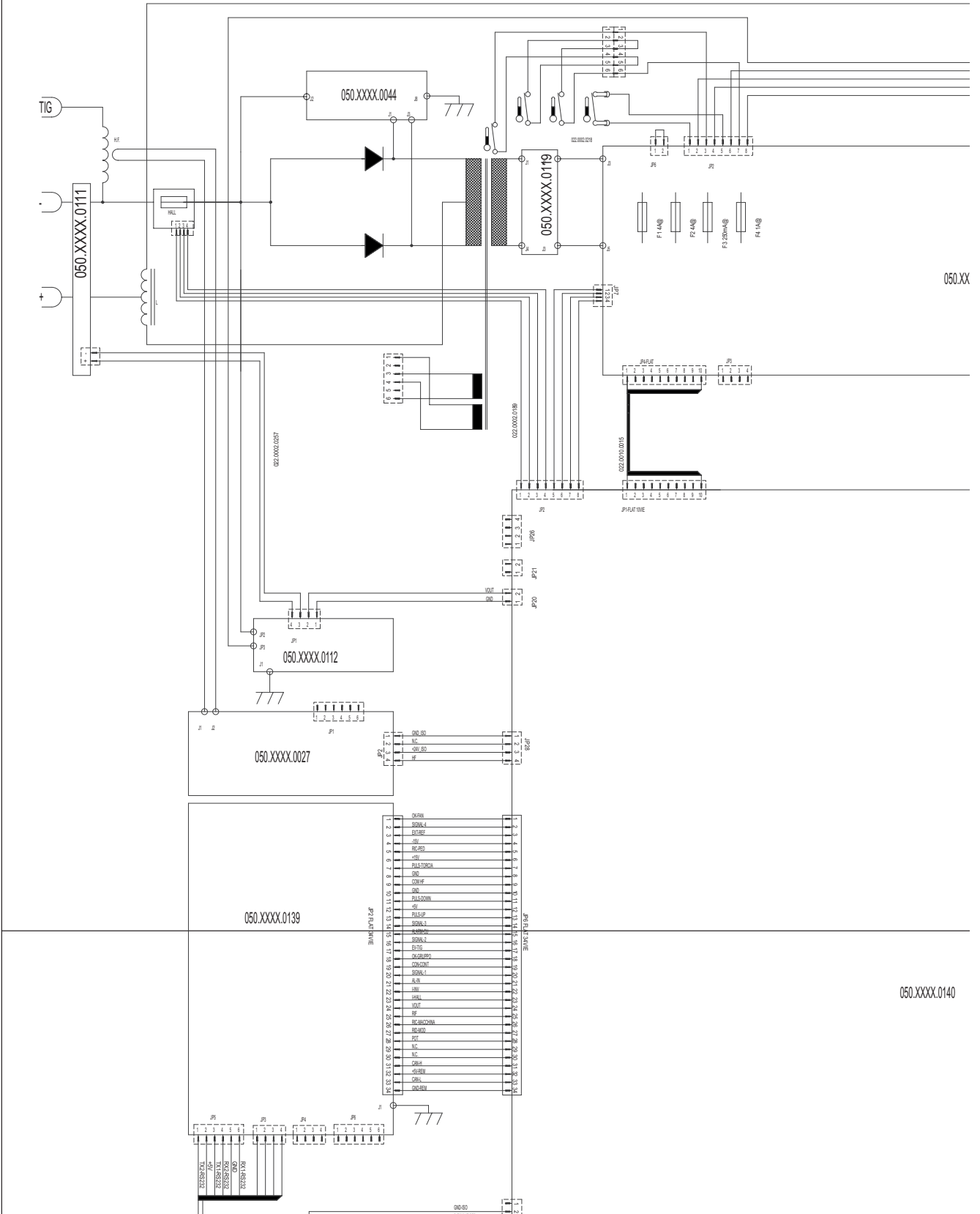

B

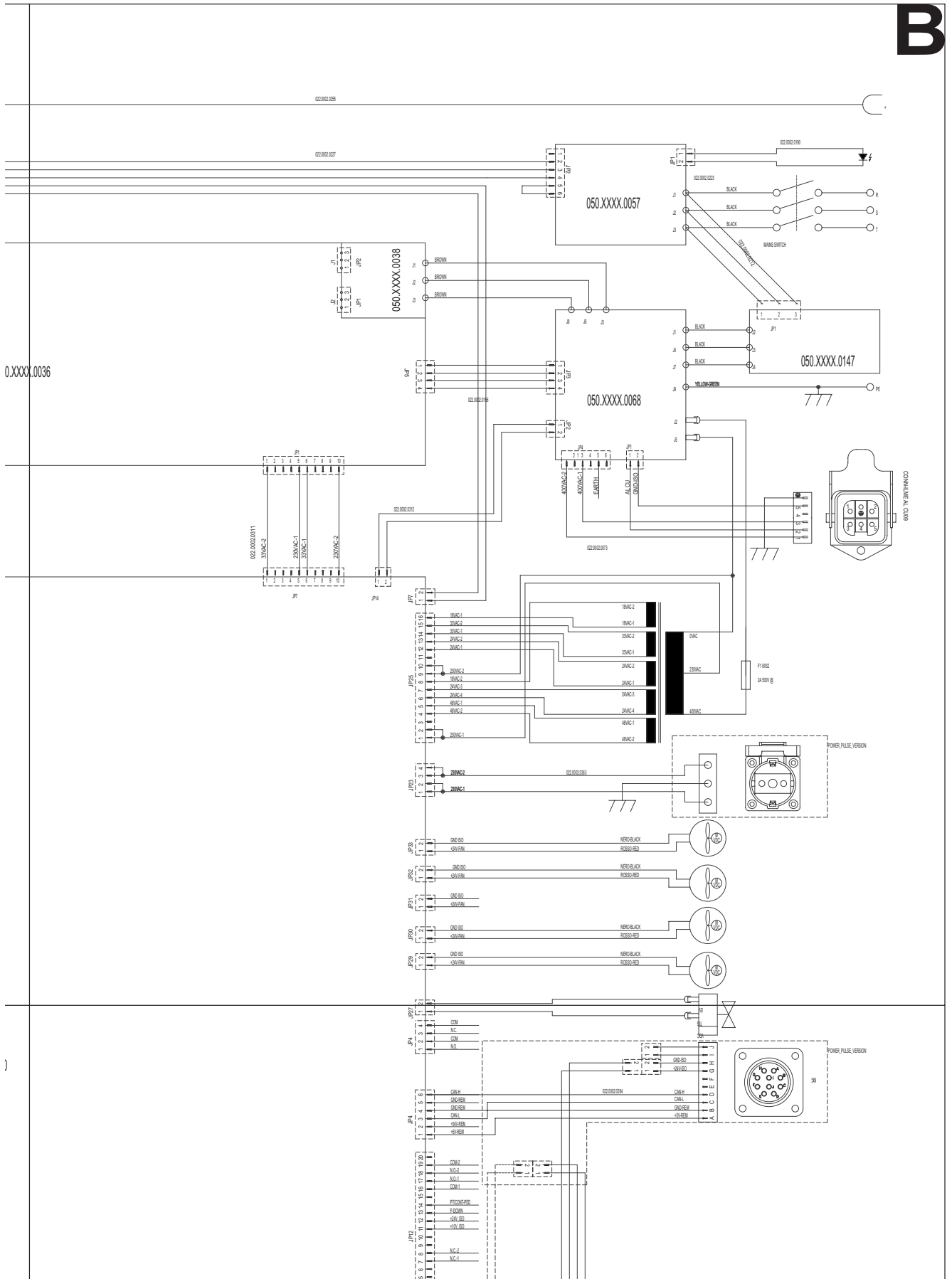



WELD THE WORLD

ENGLISH

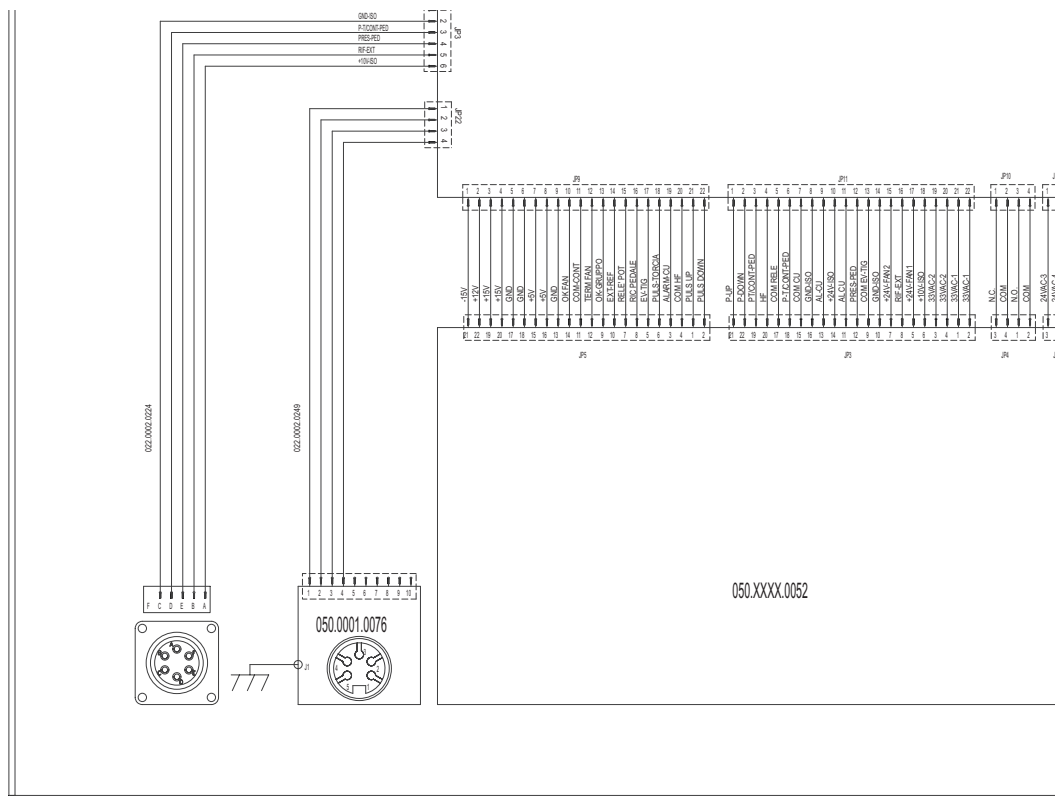

C

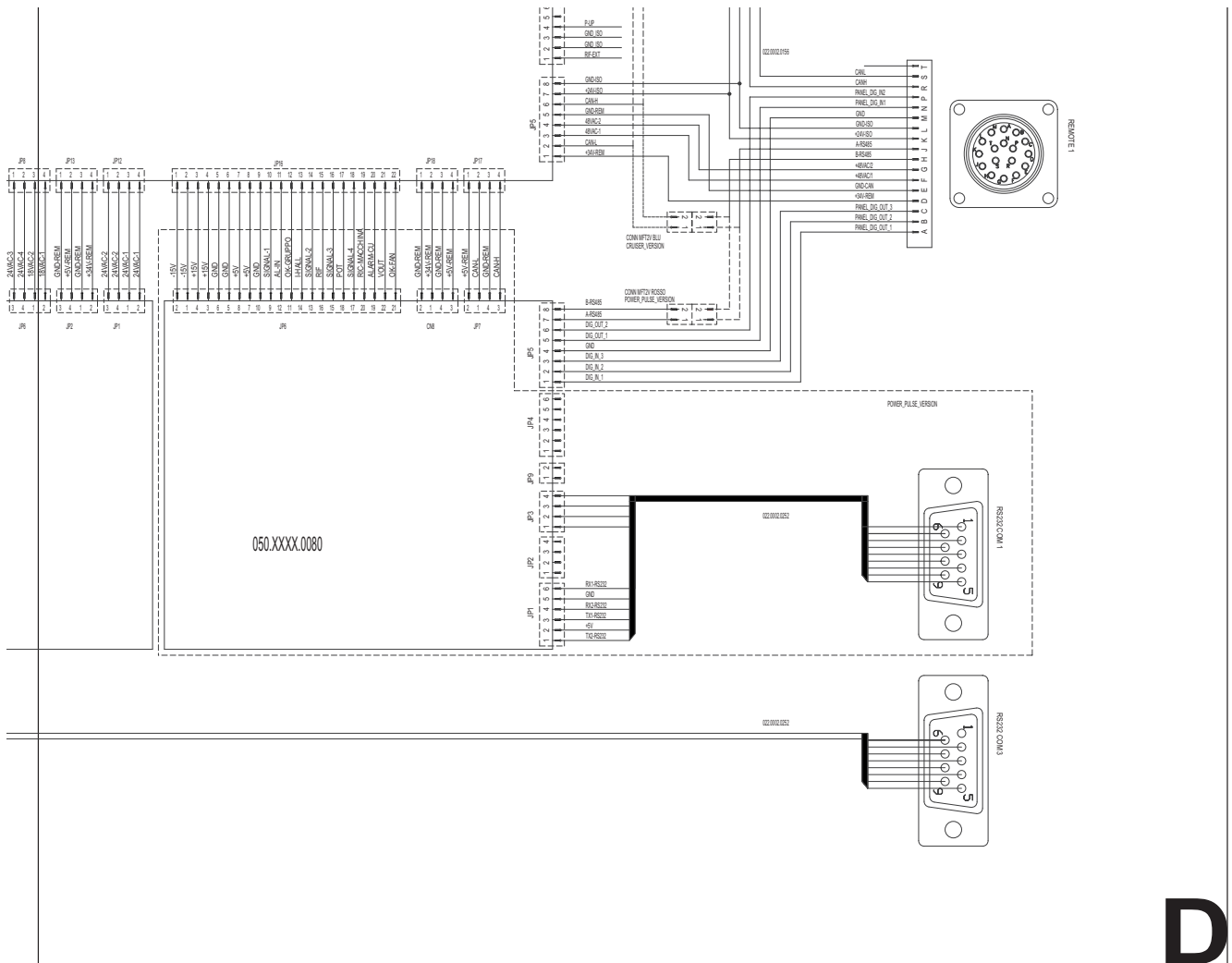

D



13.2 CRUISER 402/502T - POWER PULSE 402/502T

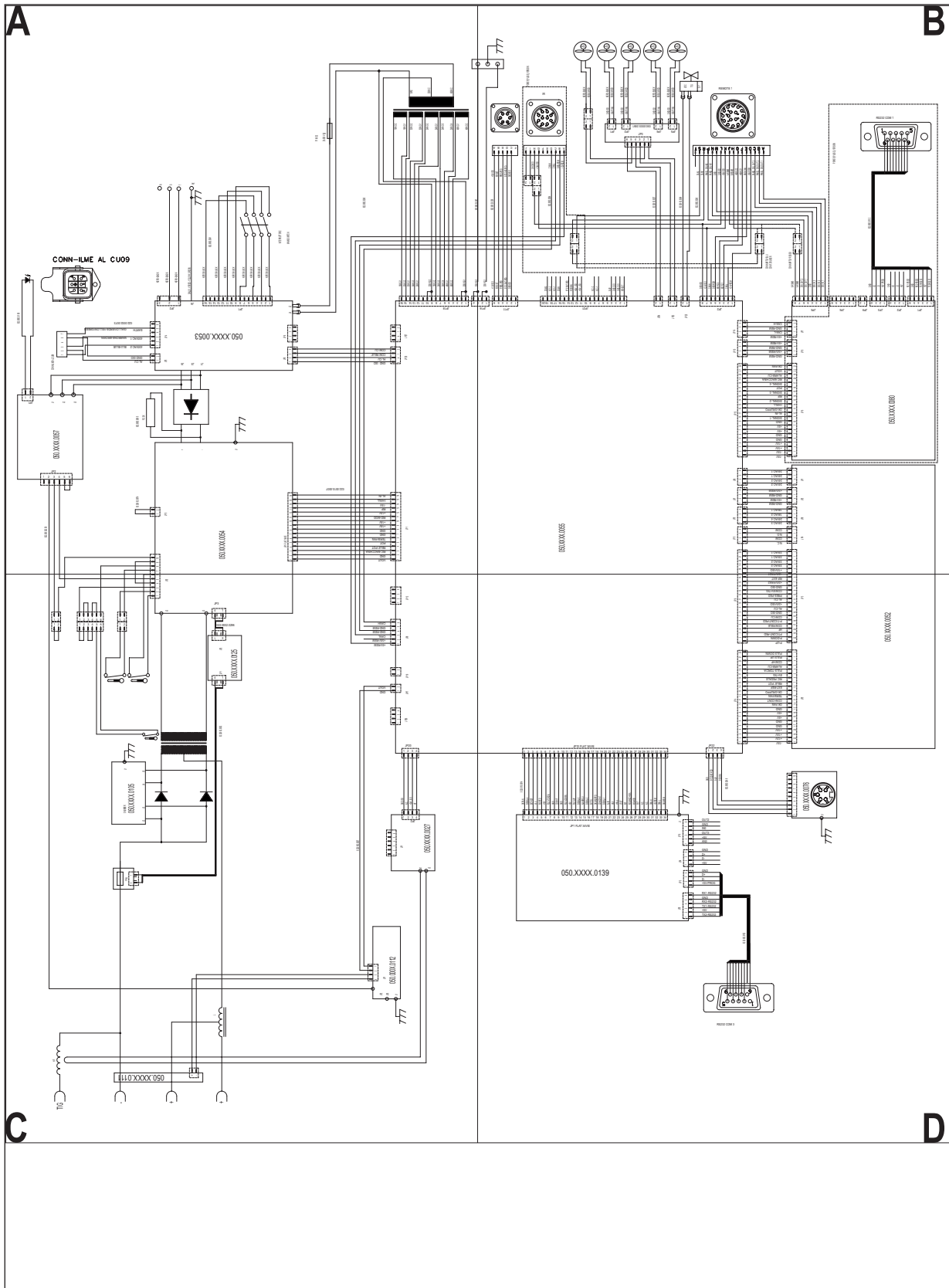

B

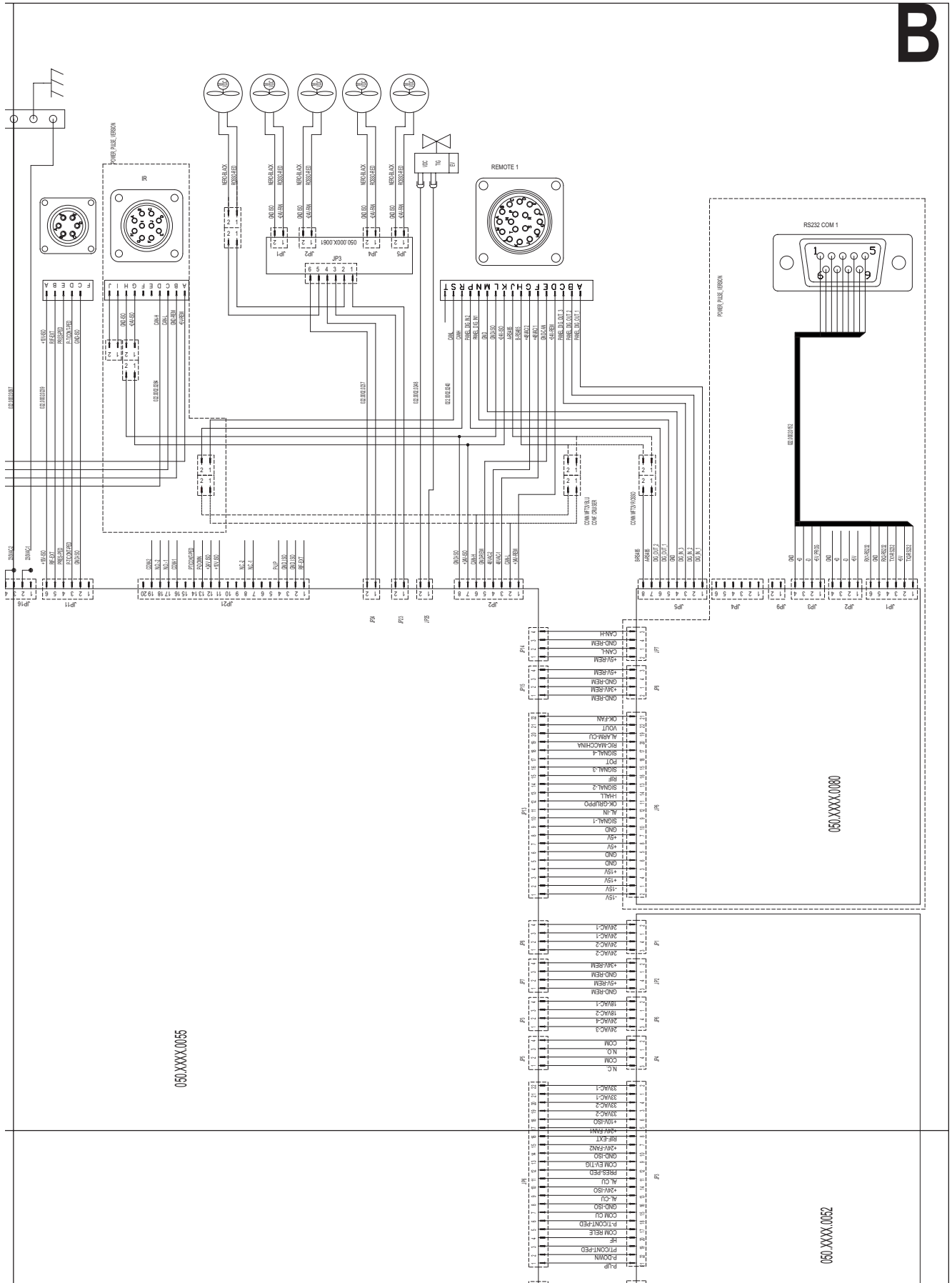

060.XXXX.0055

060.XXXX.0050

060.XXXX.0052

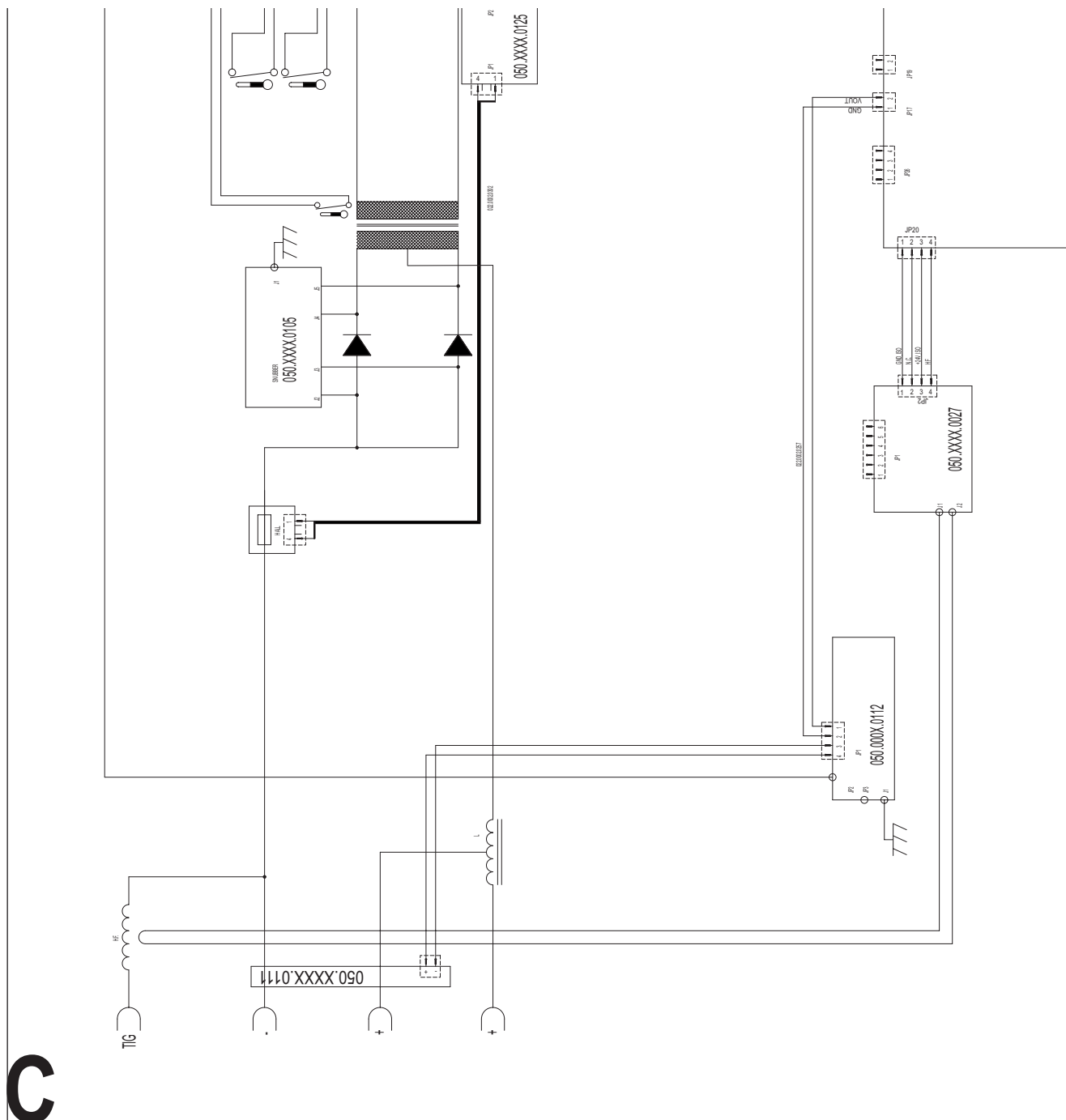

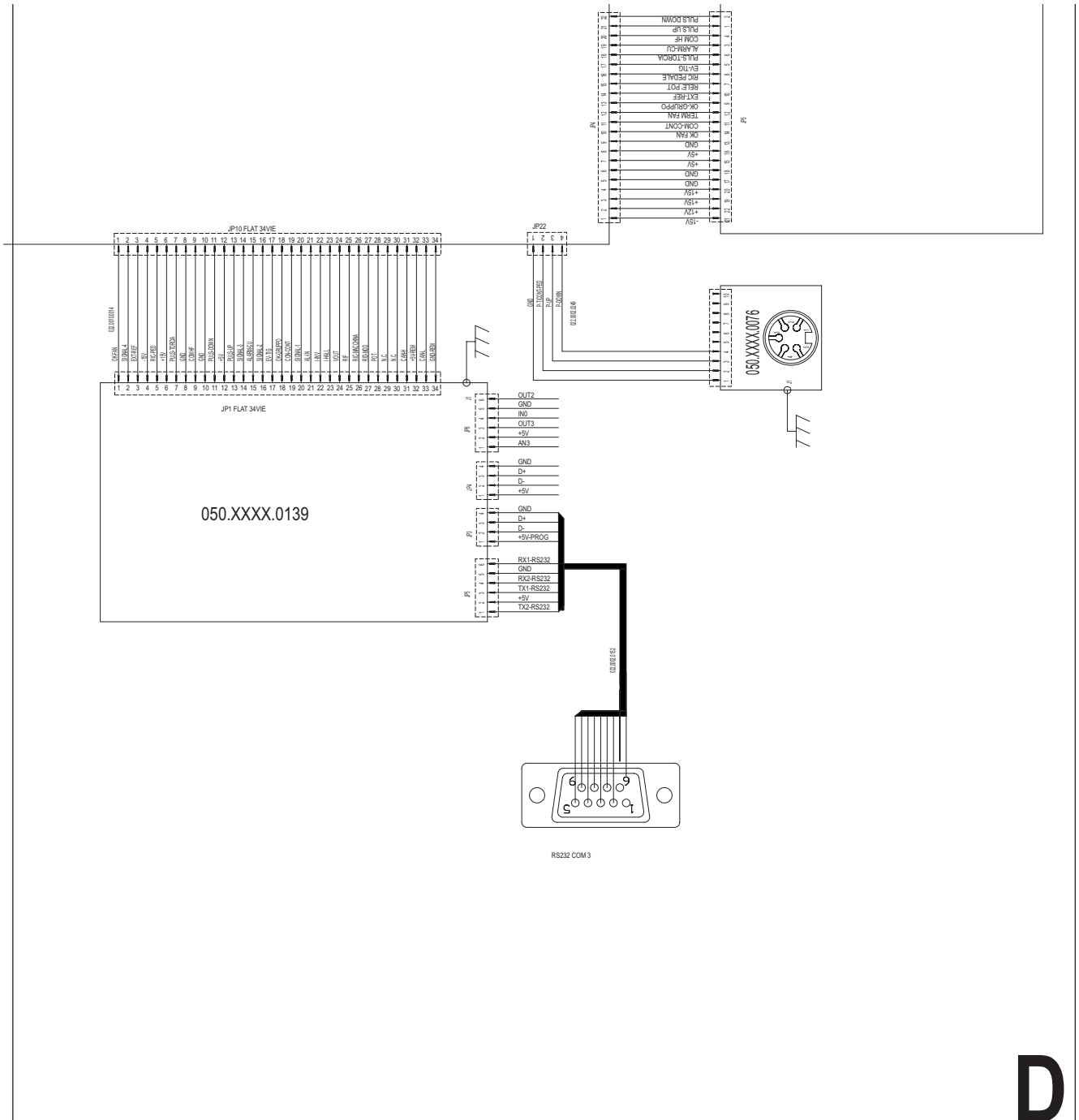

D

13.3 "REMOTE 1" CONNECTOR

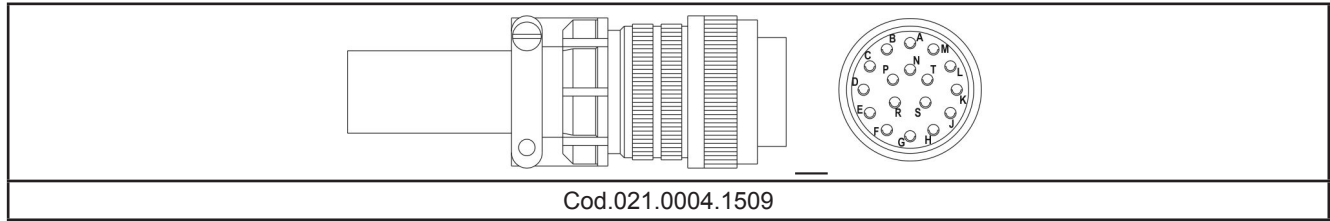

13.4 "IR" CONNECTOR

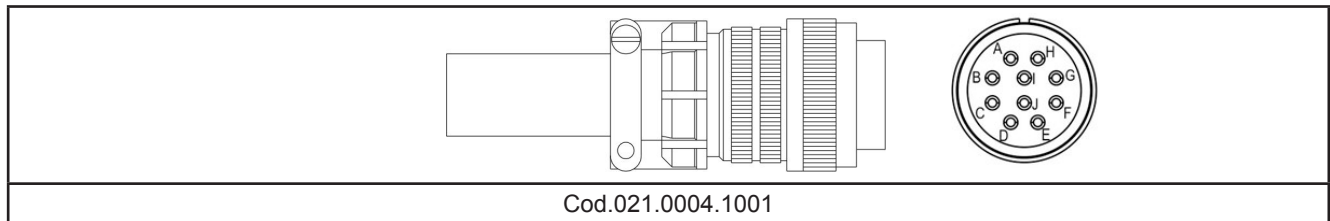

13.5 TORCH CONNECTOR (front panel)

cod. 021.0004.3360

Torch	Up/Down Torch

13.6 REMOTE CONTROL CONNECTOR (back panel)

cod. 021.0004.0602

Torch with Potentiometer Pot= 2Kohm - 10Kohm	REMOTE CONTROLLER Pot= 2Kohm - 10Kohm	FOOT PEDAL REMOTE CONTROLLER Pot= 2Kohm - 10Kohm

14 SPARE PARTS

14.1 CRUISER 322T - POWER PULSE 322T

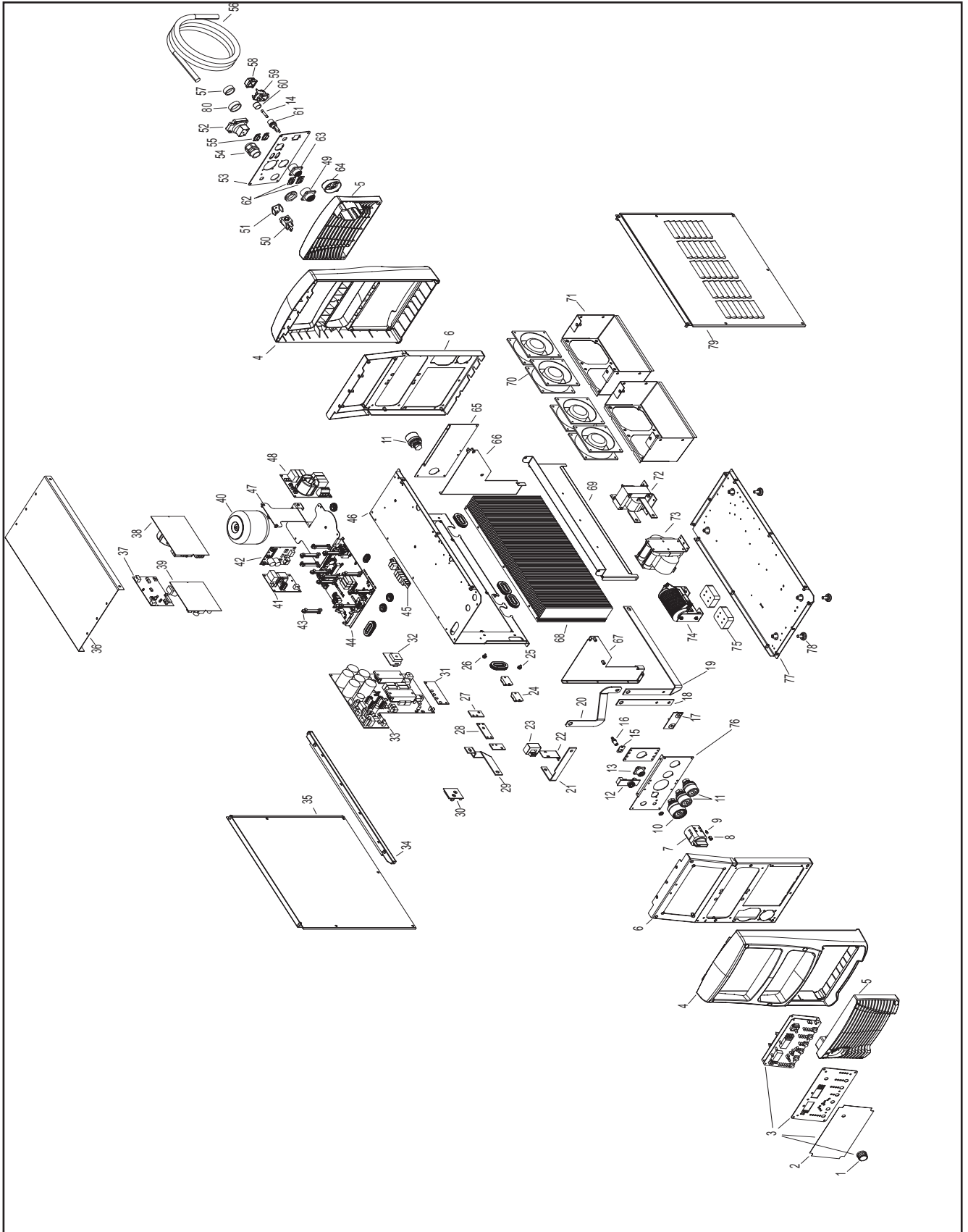

ENGLISH

N°	CODE	DESCRIPTION
1	014.0002.0010	KNOB WITH CAP
2	013.0023.0451	FRONT PANEL LABEL
3	050.5138.0000	COMPLETE LOGIC FRONT PANEL
4	012.0007.0010	FRONT/REAR PLASTIC PANEL
5	012.0007.0020	PLASTIC LOUVRE
6	011.0013.0021	FRONT/REAR PLATE
7	040.0001.0017	THREE-POLE SWITCH
8	016.4107.0001	LED HOLDER
9	022.0002.0190	LED WIRING
10	021.0001.0278	HIGH ISOLATION OUTPUT SOCKET
11	021.0001.0279	OUTPUT SOCKET
12	050.0001.0076	AMPHENOL CONNECTOR BOARD
13	022.0002.0224	REMOTE LOGIC BOARD WIRING
14	040.0007.1315	FUSE
15	011.0002.0036	SOLENOID VALVE BLOCK
16	016.5001.1132	HOSE ADAPTER
17	050.0001.0111	OUTPUT FILTER BOARD
18	045.0006.0085	(-) SOCKET COPPER BRACKET
19	045.0006.0084	(+) SOCKET COPPER BRACKET
20	045.0006.0104	HF COPPER BRACKET
21	045.0006.0098	HALL SENSOR COPPER BRACKET
22	011.0013.0041	HALL SUPPORT PLATE
23	041.0004.0501	HALL EFFECT SENSOR
24	032.0002.2403	ISOTOP DIODE
25	040.0003.1080	TERMAL SWITCH 80°C L=130mm
26	040.0003.1002	TERMAL SWITCH 75°C L=200mm
27	045.0006.0088	DIODES-TRANSFORMER COPPER BRACKET
28	045.0006.0071	(-/+) DIODE COPPER BRACKET
29	045.0006.0086	DIODES-MODULE SHORT BRACKET
30	050.0003.0044	SNUBBER BOARD
31	050.0001.0119	PRIMARY CAPACITOR BOARD
32	050.0003.0038	DIODE BRIDGE BOARD
33	050.0003.0036	COMPLETE POWER BOARD
34	011.0013.0037	COVER PANEL SUPPORT PLATE
35	011.0000.0911	LEFT COVER
36	011.0000.0901	UPPER COVER
37	050.0028.0080	"PULSE BOARD (ONLY 322 POWER PULSE VERSION)"
38	050.0002.0068	LINE FILTER BOARD
39	050.0002.0052	SUPPLIES BOARD
40	041.0006.0006	TOROIDAL TRANSFORMER
41	050.0003.0027	HF BOARD
42	050.0002.0057	POWER SUPPLY CONTROL BOARD

N°	CODE	DESCRIPTION
43	016.0010.0001	BOARDS SUPPORT GUIDE
44	050.0001.0140	BUS BOARD
45	050.0001.0112	OUTPUT FILTER BOARD
46	011.0013.0023	UPPER PLATE
47	011.0013.0044	BOARD SUPPORT PLATE
48	050.0001.0147	LINE FILTER BOARD
49	022.0002.0156	17 PIN CABLE
50	017.0001.5542	SOLENOID VALVE
51	011.0002.0018	SOLENOID VALVE PLATE
52	021.0005.0001	230V SOCKET
53	013.0000.7000	REAR PANEL
54	045.0000.0017	CABLE CLAMP
55	021.0014.0303	RS-232 CONNECTOR CAP
56	045.0002.0014	SUPPLY CABLE
57	021.0004.2993	10 PIN CONNECTOR CAP
58	021.0013.0007	ILME CONNECTOR CAP
59	022.0002.0073	CU CONNECTOR CABLE
60	016.0011.0004	FUSE HOLDER CAP
61	040.0006.1880	FUSE HOLDER
62	022.0002.0152	RS-232 CABLE
63	022.0002.0284	10 PIN CONNECTOR CABLE
64	012.0007.0040	CAP
65	011.0013.0034	REAR PLATE
66	011.0013.0040	RIGHT TUNNEL SUPP. PLATE
67	011.0013.0039	LEFT TUNNEL SUPP. PLATE
68	015.0001.0017	HEAT SINK
69	011.0013.0032	VENTILATION SHROUD
70	003.0002.0017	FAN
71	011.0013.0033	INTERNAL FAN SUPPORT
72	044.0004.0026	OUTPUT INDUCTOR
73	042.0003.0041	POWER TRANSFORMER
74	044.0003.0009	HF COIL
75	046.0004.0012	PLASTIC SUPPORT FOR HF
76	011.0013.0022	FRONT SOCKETS PLATE
77	011.0013.0020	LOWER COVER
78	016.0009.0003	RUBBER FOOT
79	011.0000.0921	RIGHT COVER
80	021.0004.2994	17 PIN CONNECTOR CAP

14.2 CRUISER 402/502T - POWER PULSE 402/502T

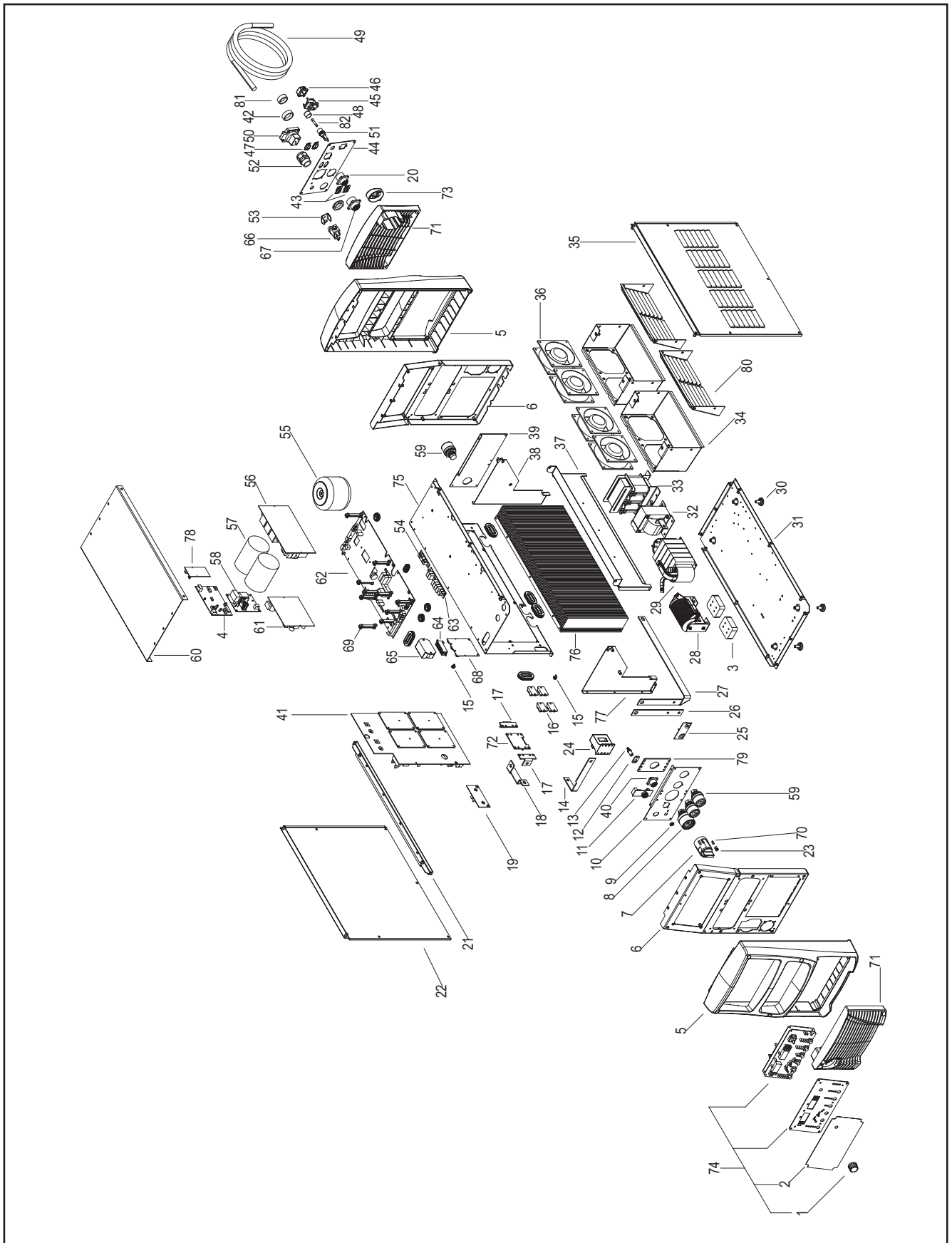

ENGLISH

N°	CODE	DESCRIPTION
1	014.0002.0010	KNOB WITH CAP
2	13.0011.0901	FRONT PANEL LABEL (402T)
	013.0011.1001	FRONT PANEL LABEL (502T)
3	046.0004.0012	PLASTIC SUPPORT FOR HF
4	050.0021.0080	PULSE BOARD (ONLY 402T POWER PULSE VERSION)
	050.0022.0080	PULSE BOARD (ONLY 502T POWER PULSE VERSION)
5	012.0007.0010	FRONT/REAR PLASTIC PANEL
6	011.0013.0021	FRONT/REAR PLATE
7	040.0001.0016	THREE-POLE SWITCH
8	021.0001.0278	HIGH ISOLATION OUTPUT SOCKET
9	016.5001.1303	RINGNUT
10	011.0013.0022	FRONT SOCKETS PANEL
11	050.0001.0076	AMPHENOL CONNECTOR BOARD
12	011.0002.0036	SOLENOID VALVE BLOCK
13	016.5001.1132	HOSE ADAPTER
14	045.0006.0098	HALL SENSOR COPPER BRACKET
15	040.0003.1007	THERMAL CUT-OUT
16	032.0002.2403	ISOTOP DIODE
17	045.0006.0090	DIODES-TRANSFORMER COPPER BRACKET
18	045.0006.0091	ISOTOP/Socket COPPER BRACKET
19	050.0001.0105	SNUBBER BOARD
20	022.0002.0284	10 PIN CONNECTOR CABLE
21	011.0013.0037	COVER PANEL SUPPORT PLATE
22	011.0000.0911	LEFT COVER PANEL
23	016.4107.0001	LED HOLDER
24	041.0004.0052	HALL EFFECT SENSOR
25	050.0001.0111	OUTPUT FILTER BOARD
26	045.0006.0085	(-) SOCKET COPPER BRACKET
27	045.0006.0084	(+) SOCKET COPPER BRACKET
28	044.0003.0009	HF COIL
29	042.0003.0042	POWER TRANSFORMER
30	016.0009.0003	RUBBER FOOT
31	011.0013.0020	LOWER COVER
32	044.0004.0024	OUTPUT INDUCTOR
33	044.0004.0022	INPUT INDUCTOR
34	011.0013.0033	INTERNAL FAN SUPPORT
35	011.0000.0921	RIGHT COVER PANEL
36	003.0002.0017	FAN
37	011.0013.0032	VENTILATION SHROUD
38	011.0013.0040	RIGHT TUNNEL SUPP. PLATE
39	011.0013.0034	REAR PLATE
40	022.0002.0239	REMOTE LOGIC CABLE

N°	CODE	DESCRIPTION
41	050.0002.0054	COMPLETE POWER BOARD
42	021.0004.2994	17 PIN CONNECTOR CAP
43	022.0002.0152	RS-232 CABLE
44	013.0000.7000	REAR PANEL
45	022.0002.0073	C.U. POWER SUPPLY WIRING
46	021.0013.0007	ILME CONNECTOR CAP
47	021.0014.0302	RS-232 CONNECTOR CAP
48	016.0011.0004	FUSE HOLDER CAP
49	045.0002.0009	SUPPLY CABLE
50	021.0005.0001	230V SOCKET
51	040.0006.1880	FUSE HOLDER
52	045.0000.0017	CABLE CLAMP
53	011.0002.0018	SOLENOID VALVE PLATE
54	050.0002.0061	FAN AND C.U. CONTROL BOARD
55	041.0006.0006	AUXILIARY TRANSFORMER
56	050.0002.0053	MAINS FILTER BOARD
57	031.1005.0228	CAPACITOR
58	050.0003.0027	HF BOARD
59	021.0001.0279	OUTPUT SOCKET
60	011.0000.0901	UPPER COVER
61	050.0002.0052	SUPPLIES BOARD
62	050.0003.0055	BUS BOARD
63	050.0001.0112	OUTPUT FILTER BOARD
64	030.0017.2202	RESISTOR
65	032.0001.8216	THREE PHASE RECTIFIER BRIDGE
66	017.0001.5542	SOLENOID VALVE
67	022.0002.0240	17 PIN CABLE
68	050.0002.0057	POWER SUPPLY CONTROL BOARD
69	016.0010.0001	BOARDS SUPPORT GUIDE
70	022.0002.0190	LED WIRING
71	012.0007.0020	PLASTIC LOUVRE
72	045.0006.0089	DIODE-DIODE BRACKET
73	012.0007.0040	CAP
74	50.5081.0000	COMPLETE FRONT LOGIC PANEL (402T)
	050.5082.0000	COMPLETE FRONT LOGIC PANEL (502T)
75	011.0013.0023	UPPER PLATE
76	015.0001.0017	HEAT SINK
77	011.0013.0039	LEFT TUNNEL SUPP. PLATE
78	050.0001.0125	CURRENT SENSOR MANAGEMENT BOARD
79	046.0004.0018	HF PLUG SUPPORT
80	011.0013.0049	INTERNAL FAN GRID
81	021.0004.2993	10 PIN CONNECTOR CAP

N°	CODE	DESCRIPTION
82	040.0007.1200	FUSE

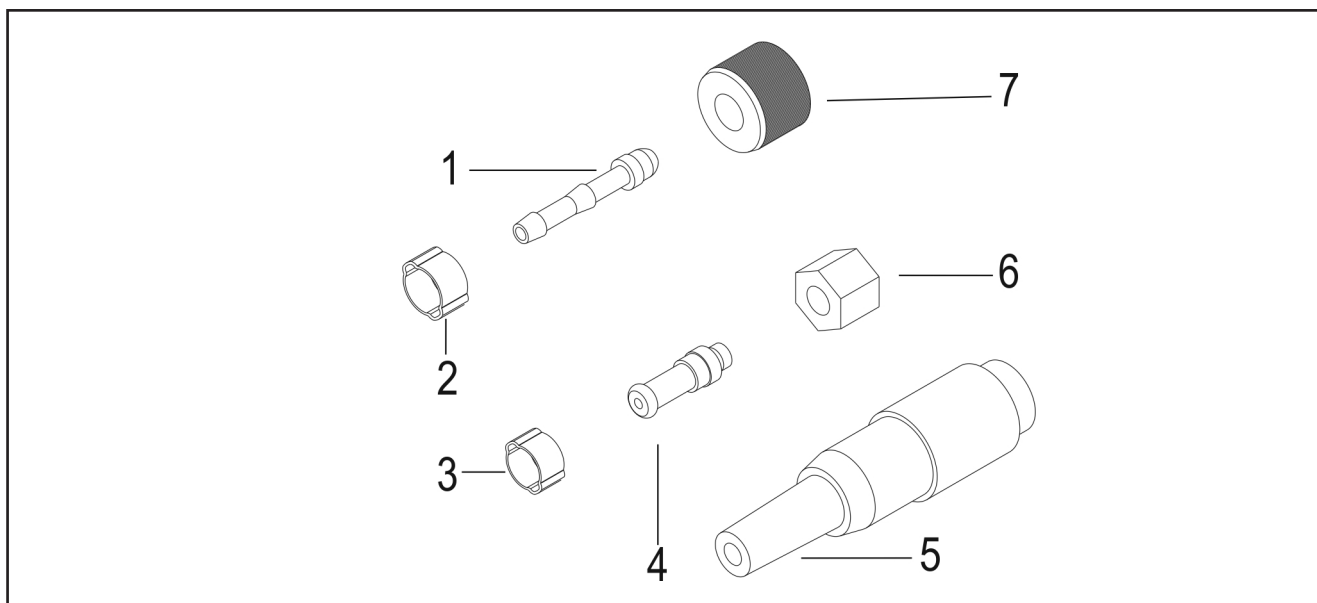

N°	CODE	DESCRIPTION
	021.0000.0001	TORCH CONNECTORS COMPLETE KIT
1	016.5001.0822	SLEEVE HOSE ADAPTER FOR RUBBER HOSE
2	016.0007.0001	HOSE CLAMP Ø=11-13
3	016.0007.0709	HOSE CLAMP Ø=07-09
4	016.5001.0821	SLEEVE HOSE ADAPTER FOR RUBBER HOSE M10
5	021.0004.3360	AMPHT3360-001 M/5V. VOL. CONNECTOR
6	016.5001.1311	NUT M10
7	016.5001.0823	NUT 1/4



WELD THE WORLD





WELD THE WORLD