



WELD THE WORLD

# Cruiser 322 AC/DC 402 AC/DC 502 AC/DC



ENG

# Cruiser 322 AC/DC

TIG AC/DC HF - MMA

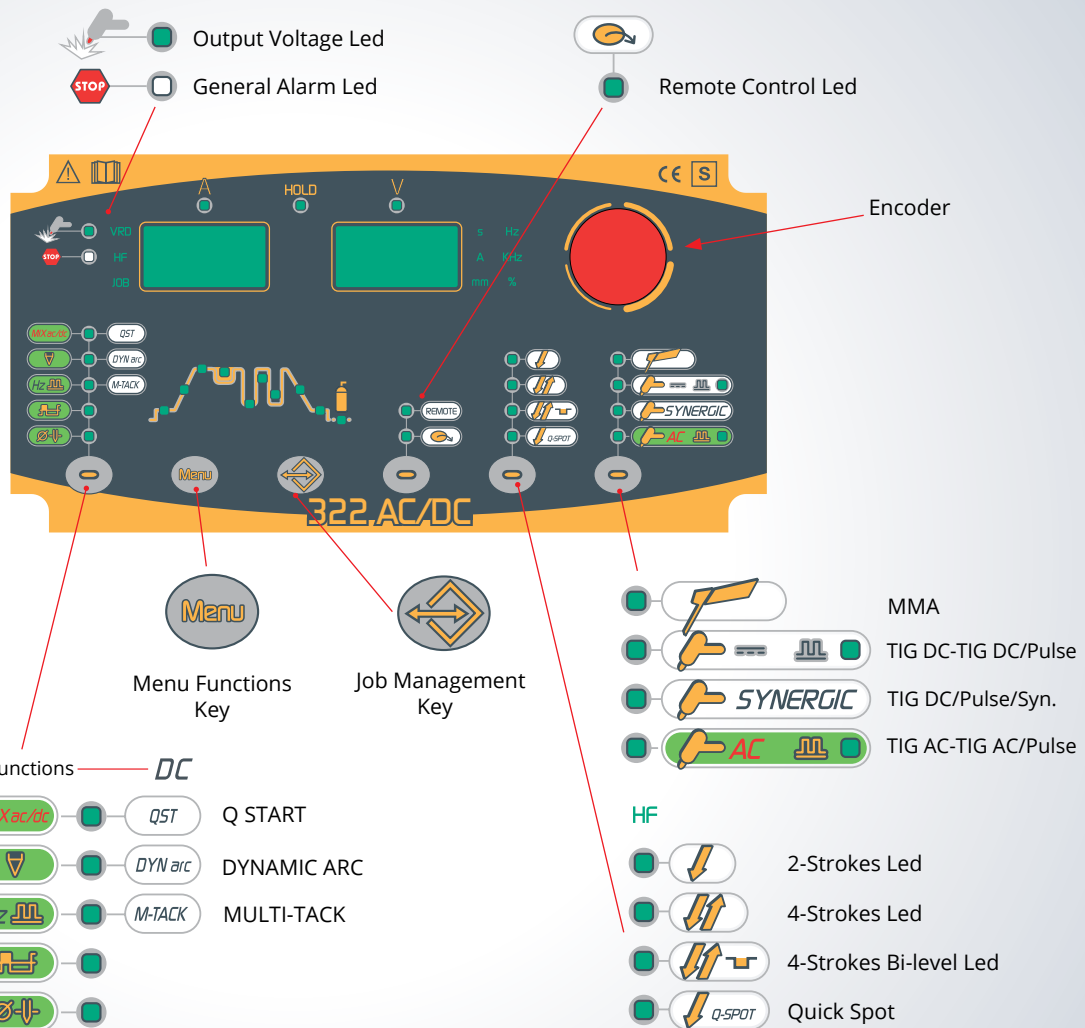

# Cruiser 322 AC/DC

## Technical Data



**The Cruiser 322AC/DC** is a high sophisticated three Phase Inverter TIG AC/DC portable welding machine. **The Cruiser 322AC/DC** has been designed particularly for extremely precise constructions, in petrochemical plants, food industry and other activities which require very high welding performance.

- 50 programs can be loaded and saved in memory
- Remote controls are available: for torch (UP&DOWN, potentiometer), foot pedal or remote control unit
- Cooling unit is also available

Cruiser 322AC/DC						
	3x400Vac ± 15% @ 50-60Hz					
	25A@					
	TIG - WIG			MMA		
$\%_{0\ 40^{\circ}\text{c}}$	45%	60%	100%	45%	60%	100%
$\cdot I_2$	320A	280A	240A	300A	270A	240A
$I_2$	5A - 320A			10A - 300A		
$U_0$	11/72V			11/72V		
$P_{I\ \text{MAX}}$	14,7kVA - 11,3kW					
IP	23					
	690 x 290 x 450mm					
	46,4Kg					

### TECHNOLOGY



### PROCESSES



TIG - WIG

MMA

### SPECIAL FUNCTIONS

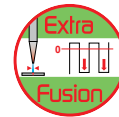
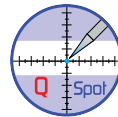

### MATERIALS



Aluminium



Mild steel



Stainless steel



Copper

### INDUSTRIES



Maintenance



Industry



Shipyard



Pipe welding

# Cruiser 402 AC/DC

TIG AC/DC HF - MMA - ARC AIR

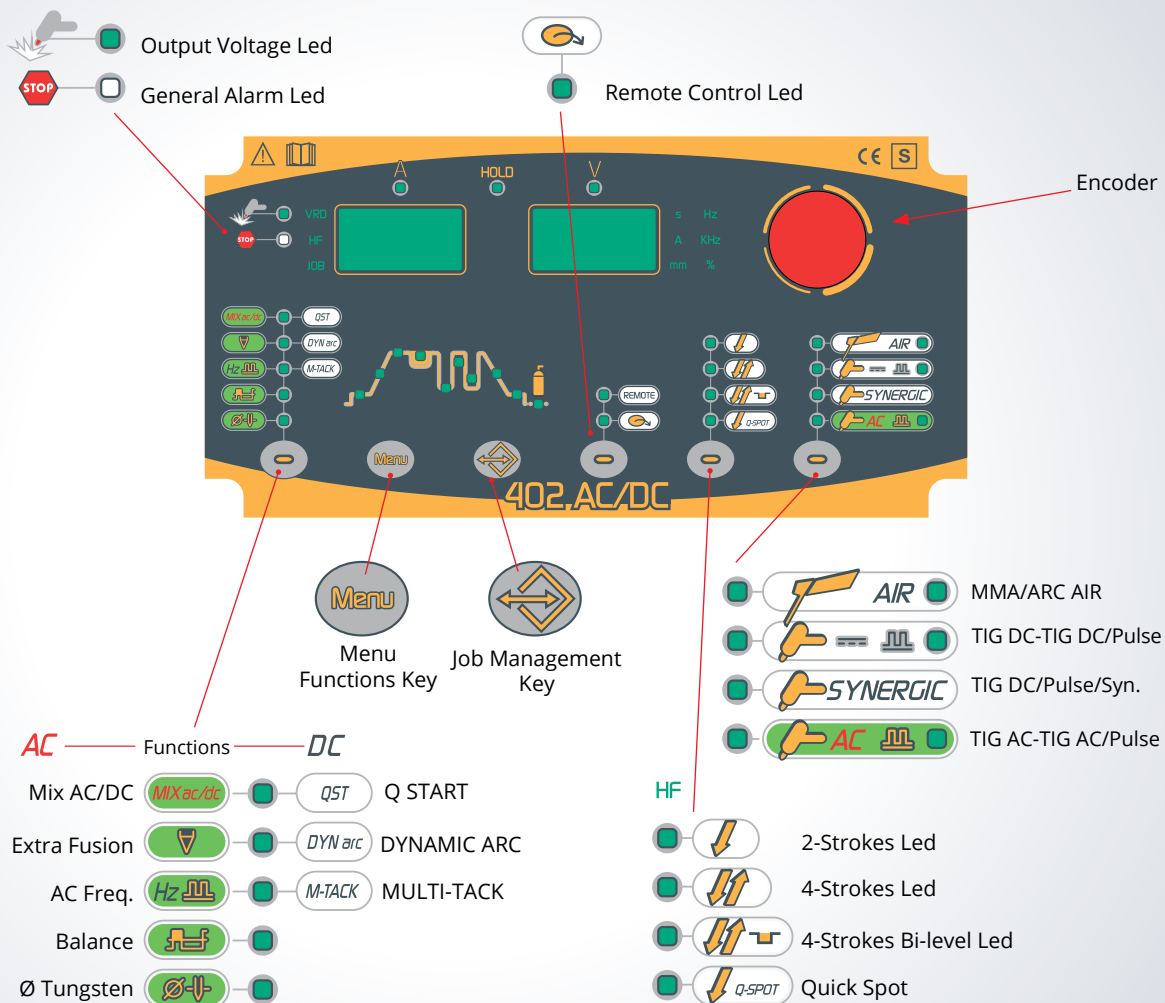

# Cruiser 402 AC/DC

## Technical Data



WELD THE WORLD

**The Cruiser 402AC/DC** is a high sophisticated three Phase Inverter TIG AC/DC portable welding machine. **The Cruiser 402AC/DC** has been designed particularly for extremely precise constructions, in petrochemical plants, food industry and other activities which require very high welding performance.

- 50 programs can be loaded and saved in memory
- Remote controls are available: for torch (UP&DOWN, potentiometer), foot pedal or remote control unit
- Cooling unit is also available
- Possibility to upgrade to multifunction

Cruiser 402AC/DC						
	3x400Vac ± 15% @ 50-60Hz					
	32A@					
	TIG - WIG			MMA		
% <sub>40°C</sub>	50%	60%	100%	50%	60%	100%
$\cdot I_2$	400A	380A	340A	400A	370A	340A
$I_2$	5A - 400A			10A - 400A		
$U_o$	9/81V					
$P_{MAX}$	18,4kVA – 16,8kW					
IP	23					
	690 x 290 x 450mm					
	56,5Kg					

### TECHNOLOGY



### PROCESSES



TIG - WIG



MMA



ARC AIR

### SPECIAL FUNCTIONS



SYN



2,5KHz



START



MULTITACK



Dynamic Arc



Spot



MIX AC/DC

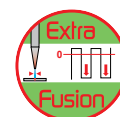

Extra Fusion

### MATERIALS



Aluminium



Mild steel



Stainless steel



Copper

### INDUSTRIES



Industry



Shipyard



Pipe welding



Heavy industry

# Cruiser 502 AC/DC

TIG AC/DC HF - MMA - ARC AIR

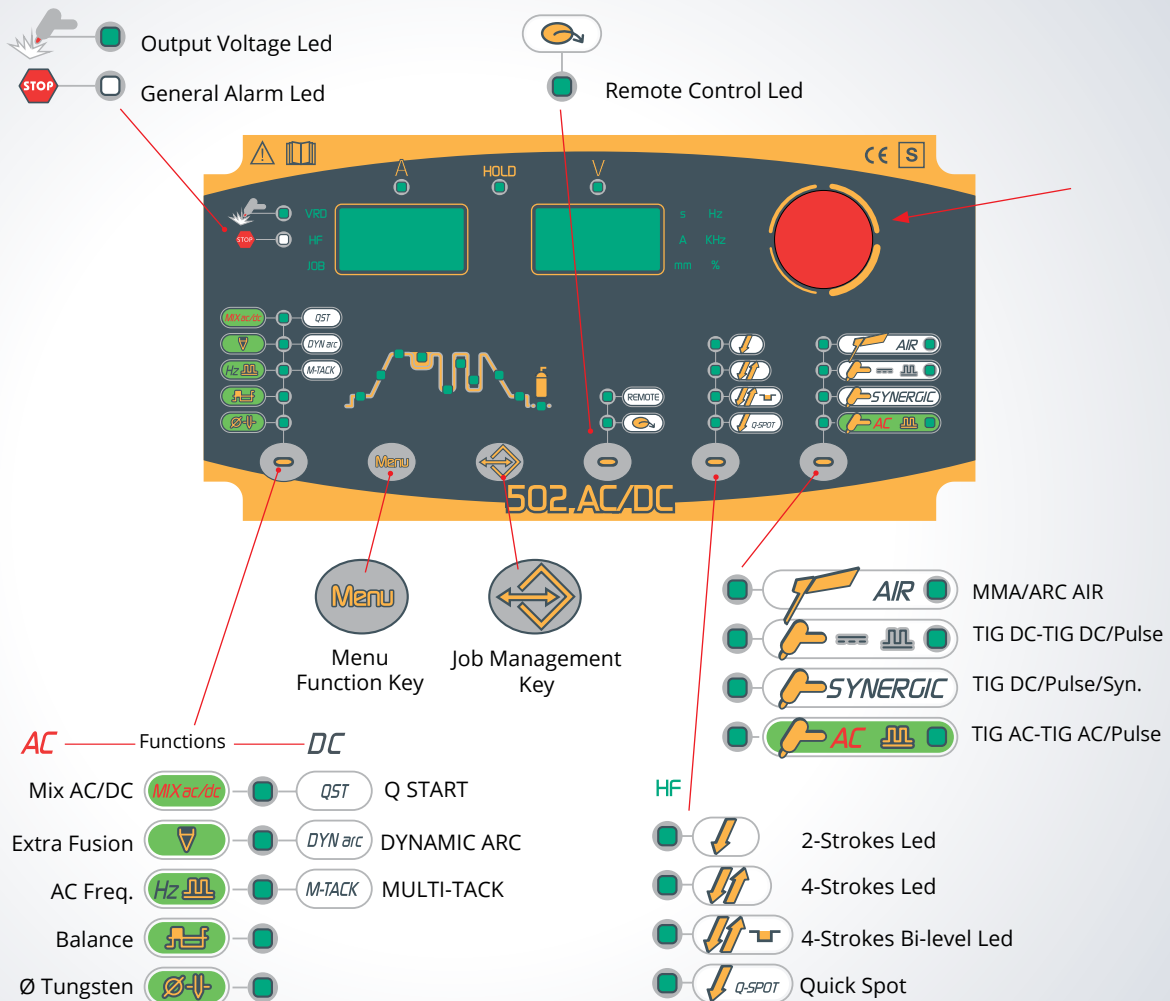

# Cruiser 502 AC/DC

## Technical Data



WELD THE WORLD

**The Cruiser 502AC/DC** is a high sophisticated three Phase Inverter TIG AC/DC portable welding machine. **The Cruiser 502AC/DC** has been designed particularly for extremely precise constructions, in petrochemical plants, food industry and other activities which require very high welding performance.

- 50 programs can be loaded and saved in memory
- Remote controls are available: for torch (UP&DOWN, potentiometer), foot pedal or remote control unit
- Cooling unit is also available
- Possibility to upgrade to multifunction

Cruiser 502AC/DC						
	3x400Vac ± 15% @ 50-60Hz					
	40A@					
	TIG - WIG			MMA		
$\%_{40^{\circ}\text{C}}$	30%	60%	100%	30%	60%	100%
$\cdot I_2$	500A	380A	340A	500A	370A	340A
$I_2$	5A - 500A			10A - 500A		
$U_0$	9/81V					
$P_{\text{MAX}}$	25,5kVA - 23,4kW					
IP	23					
	690 x 290 x 450mm					
	56,5Kg					

### TECHNOLOGY



### PROCESSES



TIG - WIG



MMA



ARC AIR

### SPECIAL FUNCTIONS



SYN



2,5KHz



START



MULTITACK



Dynamic Arc

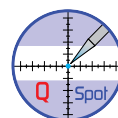

Spot



MIX AC/DC

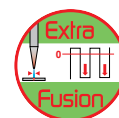

Extra Fusion

### MATERIALS



Aluminium



Mild steel



Stainless steel



Copper

### INDUSTRIES



Industry



Shipyard



Pipe welding



Heavy industry

# Cruiser 322-402-502 AC/DC

## Special Functions



This symbol highlights Weco's constant care for ecological issues and new technologies which have been introduced to reduce the environmental impact. Cruiser 322-402-502AC/DC introduce new technological solutions in order to reduce the harmonic current emissions according to the future International Standards, to increase even more the power inverter efficiency. The same welding deposit is achieved with less electrical power, less total power and less CO<sub>2</sub> emission for the safety of Planet Earth.



Pre-set balanced parameters, stored in the Synergic Pulse TIG DC SYN curve, simplify Pulsed welding by adjusting only welding current.



The pulse TIG with frequency until 2500Hz allows to weld very thin materials with easy arc control and very low heat input on workpiece.



The **Q-START** (Quick Start) function facilitates the joining of the parts in the initial stage of the welding process. On activating this function the machine automatically switches to Synergic pulsed mode for a preset time. The resulting pulses create movement of the molten metal on the two sheet metal edges thereby accelerating formation of the join. This function is invaluable in the case of seams with slight openings or with irregular preparation. The duration of the series of pulses can be adjusted, (from 0.1 to 60 second) depending on the thickness and shape of the sheet to be welded.







The **DYNAMIC ARC** function makes it possible to keep the product of Voltage x Current constant. The power source increases the welding current as the arc voltage decreases and reduces the welding current if the arc voltage increases. The DynARC value can be adjusted from a minimum of 1 Ampere to a maximum of 50 Ampere at each 1 Volt variation, whether positive or negative.

**Welding benefits of the DynARC function:**

Faster welding - Less plastic deformation of the welded part. Increased vertex angle penetration - Heat input concentrated exclusively on the weld and not on the surrounding area - Less oxidation of the part and hence reduced post-welding reworking costs - Improved control of the first root pass (helpful for plumbers and plant engineers) - Reduced risk of the electrode sticking when it touches the weld puddle - Facility to work with the electrode very close to the weld puddle in order to concentrate the arc.



Dynamic Arc TIG welding



Standard TIG welding

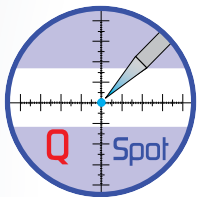

The **Q-Spot** (Quick Spot) function makes it possible to minimise tacking times for light gauge sheet metal. The operator conveniently places the tungsten electrode on the fixing point, thereby obtaining perfect control of the position of the join. Once the electrode has been lifted the machine emits a very high intensity welding current pulse with a very short preset time (from 0.01 Sec to 10 Sec). The pulse time varies depending on the type of sheet metal to be joined. In this way the welded point closes instantly with minimum heat transfer, leaving the metal white, clean and almost cold.

Pipe butt weld  
Ø 31.75 x 2 mm



Corner spot  
welding thickness  
0,6 mm

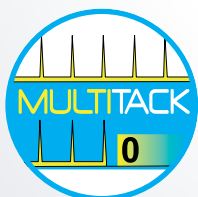

The **MULTITACK** system makes it possible to reduce heat output while joining two light gauge parts. The series of arc strikes at short time intervals allows the material to cool during the pause between one strike and the other and thus minimizes its deformation. The facility to adjust the frequency of the series of arc strikes in the time unit makes it possible to adapt the electric arc to the welding speed and the joint geometry.

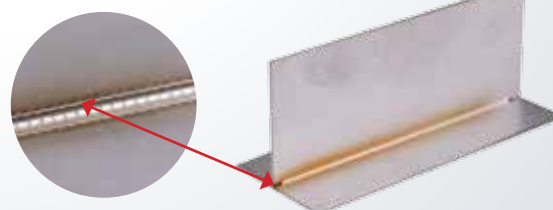

# Cruiser 322-402-502 AC/DC

## Special Functions

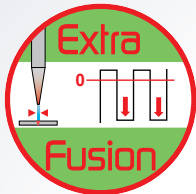

Thus function makes it possible to shift the waveform towards the negative part with respect to zero. This makes it possible to create a highly penetrative and precise fusion bath so that very light gauge sheets can be welded with an electrode tip comparable to that of an electrode for DC - TIG welding. The adjustable value in our AC/DC TIG power sources ranges from 0% to 80% (with respect to the DC - half-wave percentage).

The Extra Fusion function is not recommended when welding heavy gauges because the DC+ component is insufficient to ensure optimal cleaning (pickling) of the part during the welding process.



Fillet welding of specific 0,8mm thickness sheet



Particular on the fillet welding. It is possible to notice the remarkable degree of finishing and the high welding precision

This function **MIX AC/DC** makes it possible to modulate the welding current, alternating a half-period of TIG AC with a half-period of TIG DC. This means that the efficacy of AC TIG welding can be combined with the high penetration of DC TIG welding, thus obtaining high welding speed and creating the weld puddle rapidly on a cold workpiece. It is also possible to weld heavier gauges with lower amperage, since the DC- portion is far higher than when using an entirely AC waveform. The operator adjustable parameter is the percentage of AC waveform compared to DC- waveform over the entire period, which can be varied from 10% to 80%.

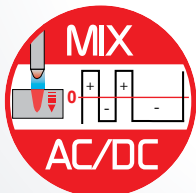

### Main benefits of MIX AC/DC:

- Welding of heavy gauge sheets with lower current than necessary when using an exclusively AC supply
- Very fast execution thanks to the high percentage of DC - current present in the period
- Very fast creation of the weld puddle (ideal for facing of tools, dies and heavy gauge castings)
- Welding of extremely diverse thickness sheets (1 mm to 10 mm).

It is good practice never to exceed the value of 50% DC - waveform, which would otherwise impair pickling of the part and the appearance of the weld bead.

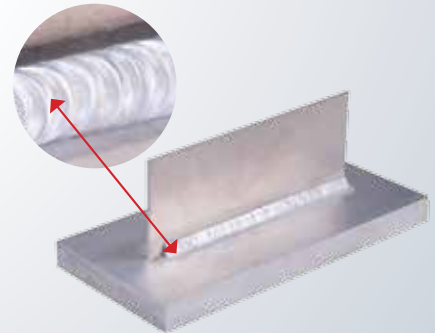

## Effects of the different wave forms by TIG AC welding

### TRIANGULAR WAVE

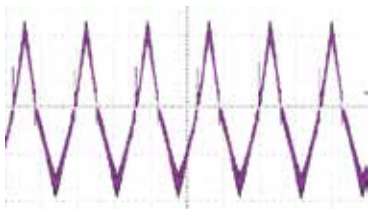

It is characterized from a particularly soft and concentrated arc. This wave form is ideal for very precise welding of thin Aluminum plates.

### SINE WAVE

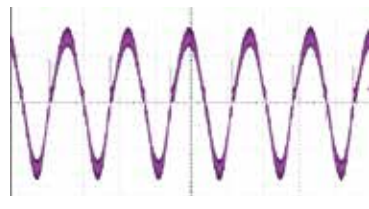

It is the standard wave form, characterized by low noise and excellent arc control.

### RECTANGULAR WAVE

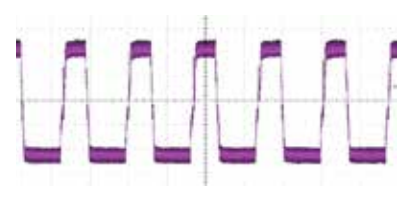

This allows a deep penetration and higher welding speed; the cleaning effect is also increased. This specific wave, compared with other rectangular waves present in the market, results to emit particular low noise.

# Cruiser 322-402-502 AC/DC

Plus and Accessories



WELD THE WORLD



## PLUS



### STRUCTURAL STRENGTH

The structural strength of the Cruiser 322 - 402 - 502AC/DC is very robust in any working environment.



### ROBUST WHEELS

The robust wheels of the Cruiser 322 - 402 - 502AC/DC allows smooth movement of the power source.



### EASY CARRIAGE

The Cruiser 322 - 402 - 502AC/DC can be easily moved around any workplace thanks to our robust trolley.

## ACCESSORIES

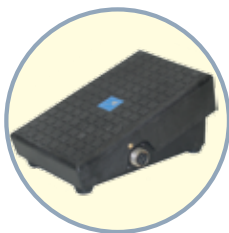

FOOT PEDAL



SOFTWARE UPGRADE OF THE WHOLE MACHINE



UP & DOWN TORCH

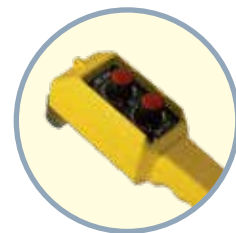

REMOTE CONTROL

**A solid industrial activity, where the production is based on substantial investments for the supporting of research, projection and continuous testing.**

Since 1997 Weco has been producing and selling welding machines

Both registered office and production plant are based on the north east of Italy. Our offices, technical/project department, production and warehouse are able to serve both our national and international sales net. A wide range of welding machines together with a huge stock, allow us to encounter and fully satisfy our customers' requests in short time.

A dynamic management supported by solid experience on the main sales' arguments and a deep knowledge on the application issues, allow this company to be ahead in the welding sector.

WECO means better solution for improving the production, optimizing the intervention time, minimizing the processes' costs, with the highest perform-standards granted.



**WELD THE WORLD**