



Pioneer

403MSR 503MSR

WELD THE WORLD

Instruction manual



Translation of original instructions



ENG



INDEX

1	INTRODUCTION	4
1.1	INTRODUCTION.....	5
2	INSTALLATION	6
2.1	CONNECTIONS TO THE ELECTRICAL MAINS NETWORK.....	6
2.2	FRONT PANEL.....	6
2.3	REAR PANEL.....	7
3	USER INTERFACE	8
4	TECHNICAL DATA	9
5	PIONEER 403/503MSR→WF CABLE	12
6	ELECTRICAL DIAGRAM	13
7	SPARE PARTS	18

1 INTRODUCTION

 	IMPORTANT!
<p><i>This handbook must be consigned to the user prior to installation and commissioning of the unit. Read the "General prescriptions for use" handbook supplied separately from this handbook before installing and commissioning the unit.</i></p> <p><i>The meaning of the symbols in this manual and the associated precautionary information are given in the "General prescriptions for use".</i></p> <p><i>If the "General prescriptions for use" are not present, it is mandatory to request a replacement copy from the manufacturer or from your dealer.</i></p> <p><i>Retain these documents for future consultation.</i></p>	

LEGEND

	DANGER!
<i>This pictogram warns of danger of death or serious injury.</i>	

	WARNING!
<i>This pictogram warns of a risk of injury or damage to property.</i>	

	CAUTION!
<i>This pictogram warns of a potentially hazardous situation.</i>	

	INFORMATION
<i>This pictogram gives important information concerning the execution of the relevant operations.</i>	

- ➡ This symbol identifies an action that occurs automatically as a result of a previous action.
- ① This symbol identifies additional information or a reference to a different section of the manual containing the associated information.
- § This symbol identifies a reference to a chapter of the manual.
- *1 The symbol refers to the associated numbered note.

NOTES

The figures in this manual are purely guideline and the images may contain differences with respect to the actual equipment to which they refer.

1.1 INTRODUCTION

PIONEER 403-503MSR is a power source for welding.
When combined with a wire feeder it can be used for MIG/MAG welding.

Fan. The fan is turned on only during welding, at the end of the welding process it remains on for a fixed period of time according to welding conditions.
The fan is nonetheless controlled by specific thermal sensors that guarantee a correct cooling of the machine.

Accessories/ancillary devices that can be connected to the unit:

- Power source trolley for multi-function configuration (MIG/MAG).
- Liquid cooler for MIG/MAG torches.
- Wire feeder.

Consult your dealer for an updated list of accessories and the latest new products available.

2 INSTALLATION



DANGER! **Lifting and positioning**

Read the warnings highlighted by the following symbols in the “General prescriptions for use”.

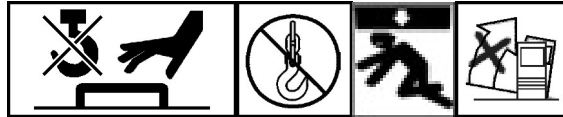

2.1 CONNECTIONS TO THE ELECTRICAL MAINS NETWORK

The mains power supply features to which the equipment should be connected are given in chapter “TECHNICAL DATA”.

The machine can be connected to motorgenerators provided their voltage is stabilised.
Connect/disconnect the various devices with the machine switched off.

2.2 FRONT PANEL

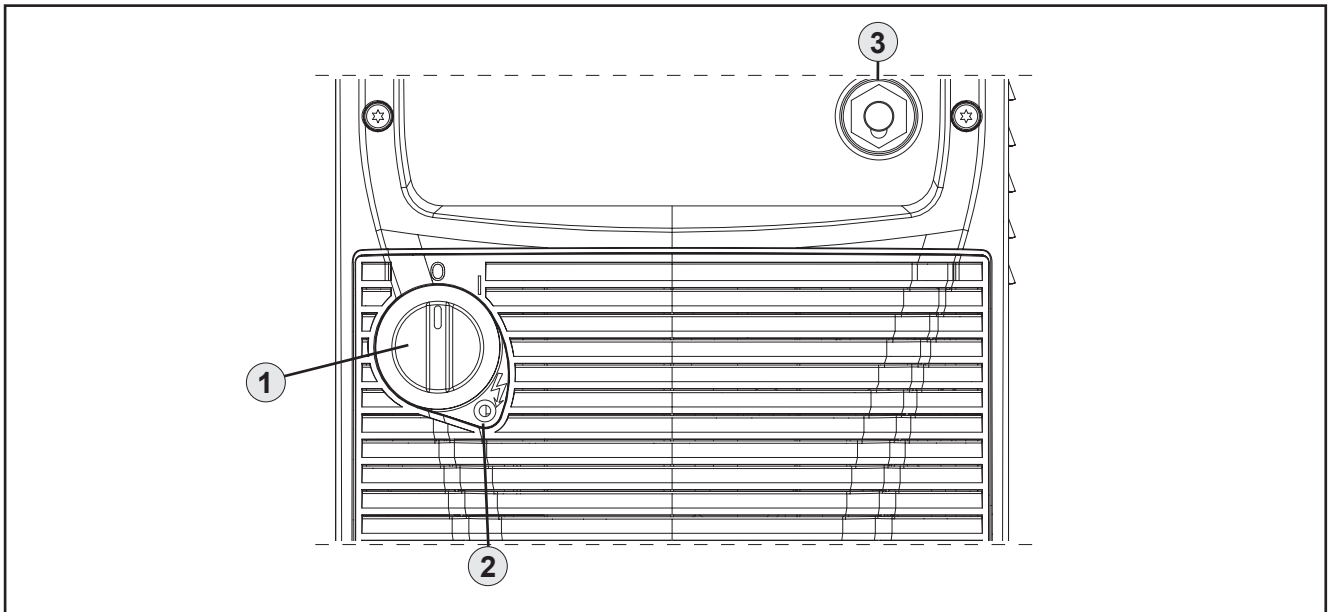

- Welding power source ON/OFF switch. [Item 1].
- Mains protection ON LED [Item 2].
- Earth welding socket [Item 3].

2.3 REAR PANEL

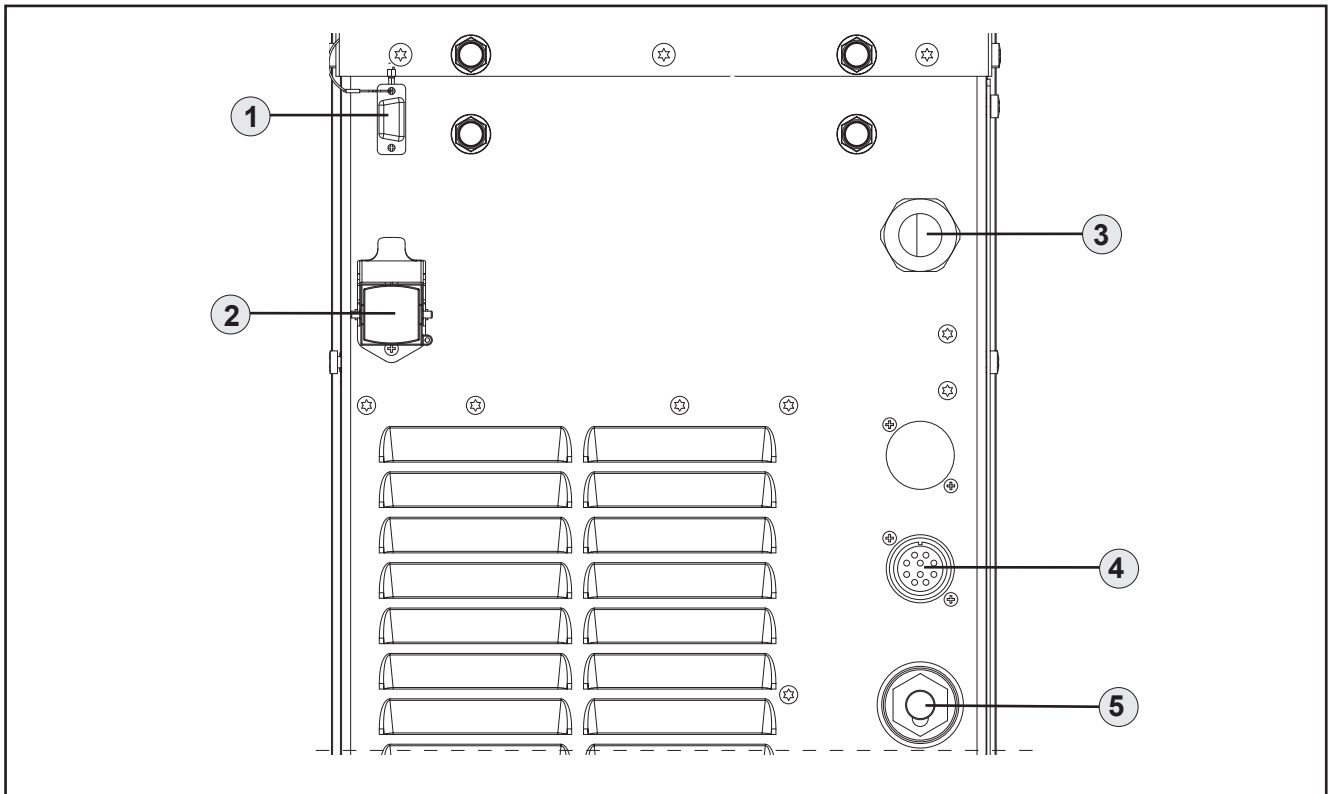

- Connector for connection to the programmer [Item 1]. Programming connector for the “pulsed” circuit board. You can update the software of the equipment using the programming kit.
- Cooler group power feeding connector [Item 2].
 - Voltage: 400 V a.c.
 - Current output: 1.0 A
 - IP protection rating: IP20 (cap open) / IP66 (cap closed)



DANGER!
High voltage!

If the socket is not connected to any devices always close cap

- Power cable [Item 3].
 - Total length (external part): 4,3 m
 - Number and cross section of wires: 4 x 6 mm²
 - Power plug type: not supplied
- Connector of the bundle of cables for connecting the power source to the remote control device [Item 4].
- Socket for connecting the power cable between the power source and the remote control device [Item 5].



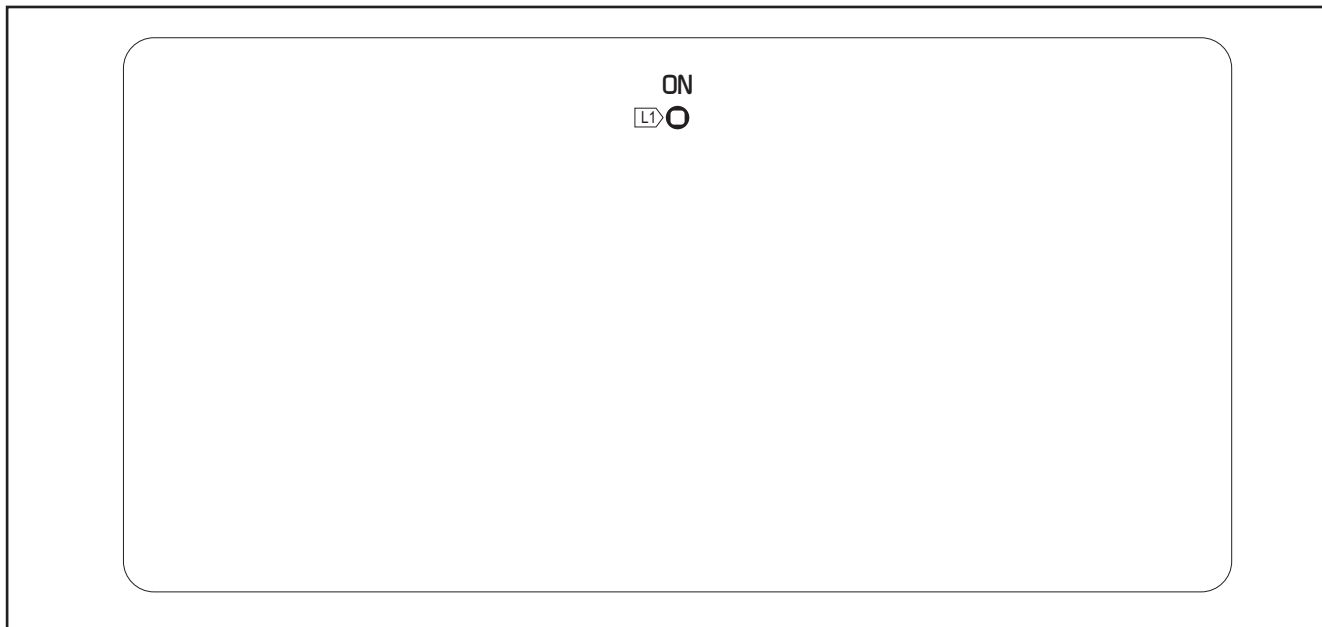

3 USER INTERFACE

PIONEER 403-503MSR



CODE	SYMBOL	DESCRIPTION
L1	ON	This LED illuminates to confirm the presence of power on the output sockets.

4 TECHNICAL DATA

Directives applied	Waste electrical and electronic equipment (WEEE)	
	Electromagnetic compatibility (EMC)	
	Low voltage (LVD)	
	Restriction of the use of certain hazardous substances (RoHS)	
Construction standards	EN 60974-1; EN 60974-10 Class A	
Conformity markings	 Equipment compliant with European directives in force	
	 Equipment suitable in an environment with increased hazard of electric shock	
	 Equipment compliant with WEEE directive	
	 Equipment compliant with RoHS directive	
Supply voltage	3 x 400 Va.c. ± 15 % / 50-60 Hz	
Mains protection	32 A 500 V Delayed	
Zmax	This equipment complies with IEC 61000-3-12 provided that the maximum permissible system impedance is less than or equal to 68 mΩ at the interface point between the user's supply and the public system. It is the responsibility of the installer or user of the equipment to ensure, by consultation with the distribution network operator if necessary, that the equipment is connected only to a supply with maximum permissible system impedance less than or equal to 68 mΩ.	
Dimensions (L x D x H)	1370 x 460 x 990 mm	
Weight	46 kg	
Insulation class	H	
Protection rating	IP23	
Cooling	AF: Air-over cooling (fan assisted)	
	MIG/MAG  Flat characteristic	
Welding mode		MIG/MAG
Current and voltage adjustment range		10 A / 14.5 V 500 A / 39.0 V
Welding current / Working voltage	30% (40° C)	500 A / 39.0 V
	60% (40° C)	430 A / 35.5 V
	100% (40° C)	400 A / 34.0 V
Maximum input power	30% (40° C)	25.1 kVA - 22.4 kW
	60% (40° C)	19.7 kVA - 17.0 kW
	100 % (40° C)	17.7 kVA - 15.2 kW
Maximum supply current	30% (40° C)	36.0 A
	60% (40° C)	27.8 A
	100 % (40° C)	25.5 A
Maximum Effective Supply Current	30% (40° C)	19.7 A
	60% (40° C)	21.5 A
	100 % (40° C)	25.5 A
No-load voltage (U0)		<u>62V</u>
Reduced no-load voltage (Ur)		<u>10V</u>

ENGLISH

Supply voltage	3 x 400 Va.c. ± 15 % / 50-60 Hz	
Mains protection	32 A 500 V Delayed	
Zmax	This equipment complies with IEC 61000-3-12 provided that the maximum permissible system impedance is less than or equal to 21 mΩ at the interface point between the user's supply and the public system. It is the responsibility of the installer or user of the equipment to ensure, by consultation with the distribution network operator if necessary, that the equipment is connected only to a supply with maximum permissible system impedance less than or equal to 21 mΩ.	
Dimensions (L x D x H)	1370 x 460 x 990 mm	
Weight	46 kg	
Insulation class	H	
Protection rating	IP23	
Cooling	AF: Air-over cooling (fan assisted)	
	MIG/MAG  Flat characteristic	
Welding mode		MIG/MAG
Current and voltage adjustment range		10 A / 14.5 V 400 A / 34.0 V
Welding current / Working voltage	30% (40° C)	-
	60% (40° C)	-
	100% (40° C)	400 A / 34.0 V
Maximum input power	30% (40° C)	-
	60% (40° C)	-
	100 % (40° C)	17.7 kVA - 15.2 kW
Maximum supply current	30% (40° C)	-
	60% (40° C)	-
	100 % (40° C)	25.5 A
Maximum Effective Supply Current	30% (40° C)	-
	60% (40° C)	-
	100 % (40° C)	25.5 A
No-load voltage (U0)		<u>62V</u>
Reduced no-load voltage (Ur)		<u>10V</u>



5 PIONEER 403/503MSR → WF CABLE

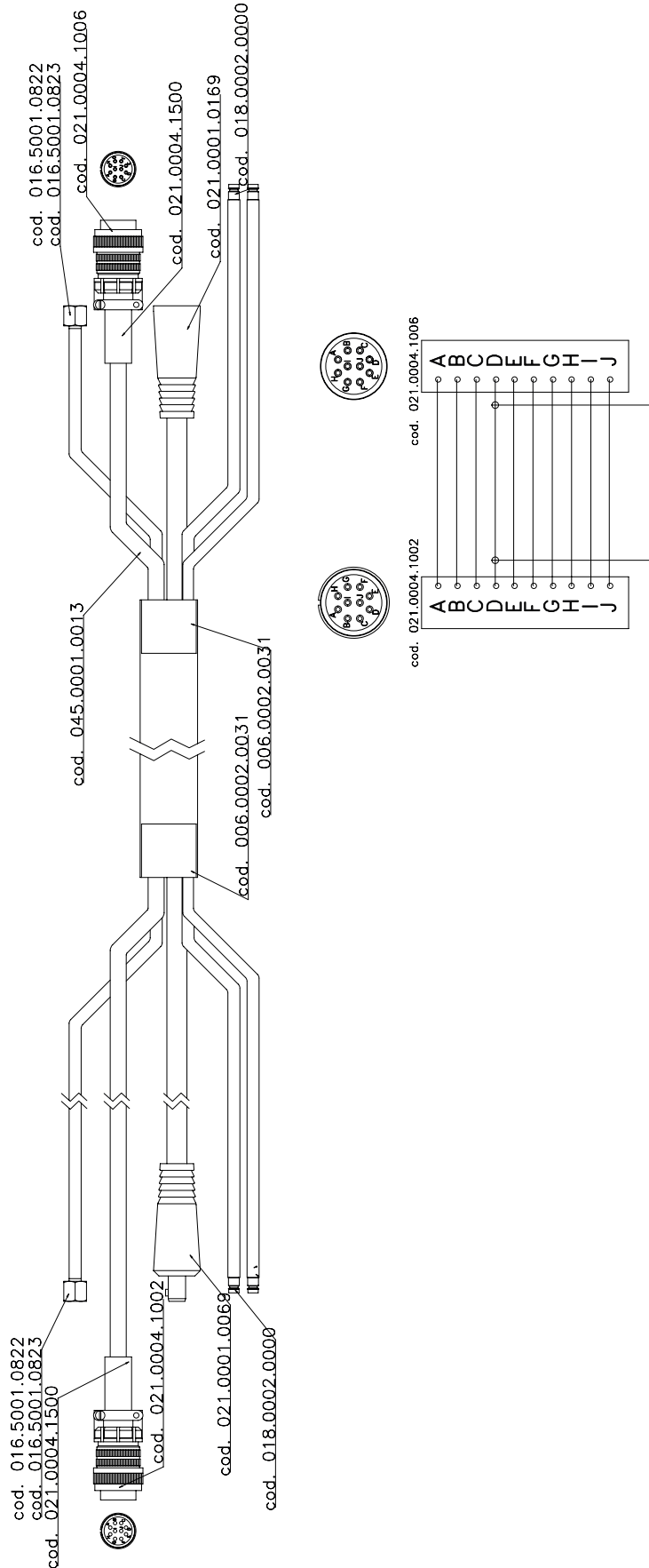

6 ELECTRICAL DIAGRAM

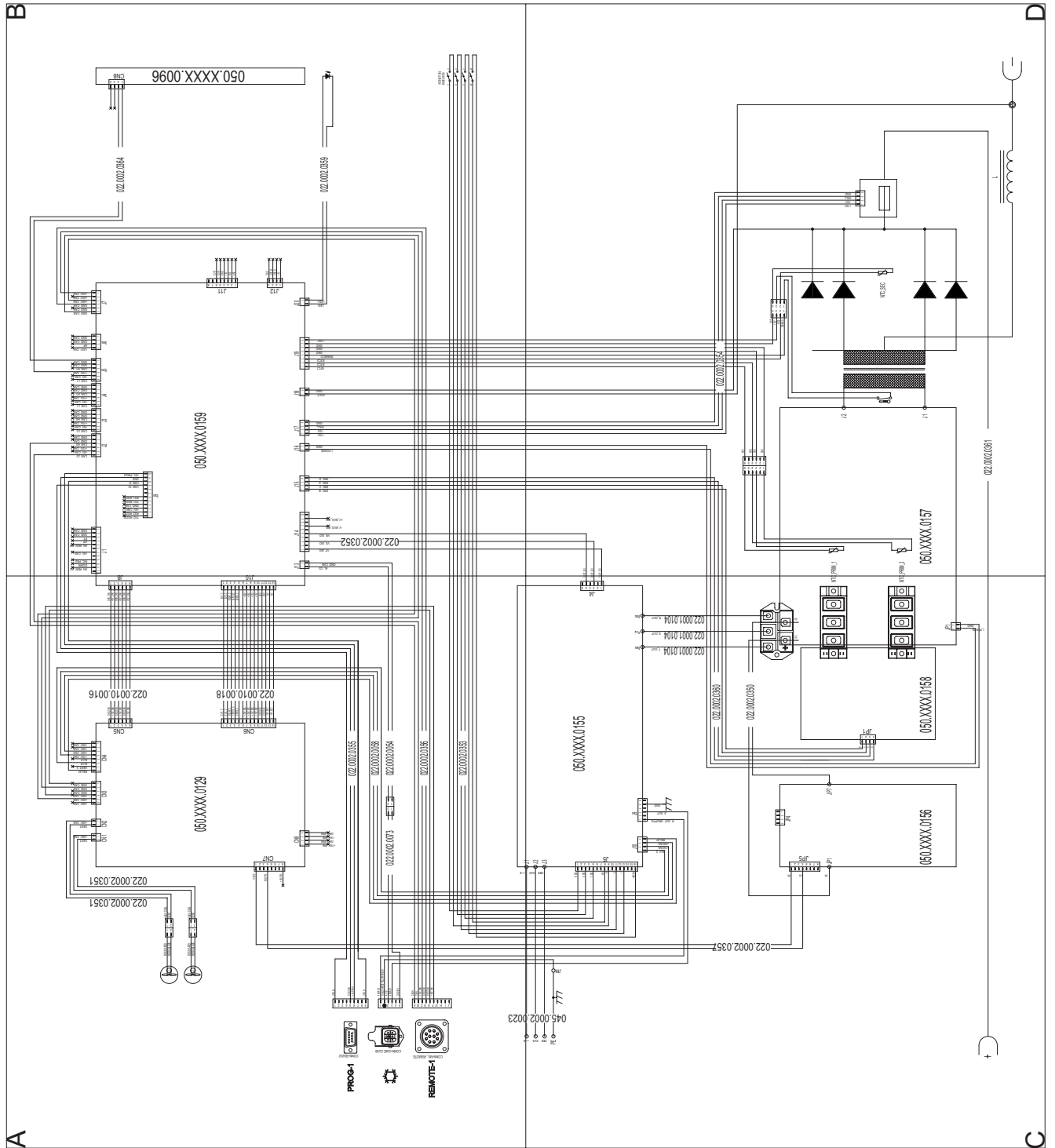

B

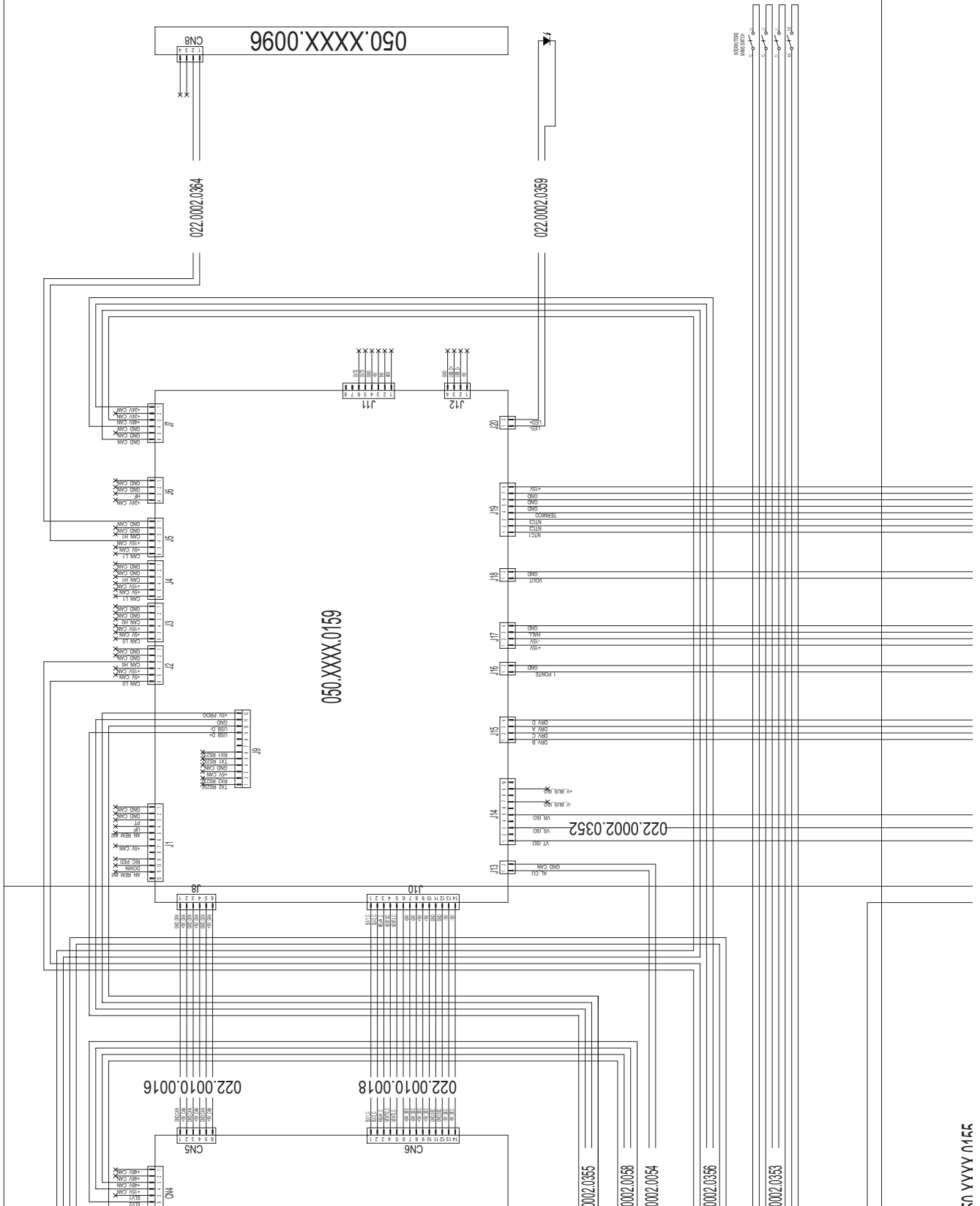

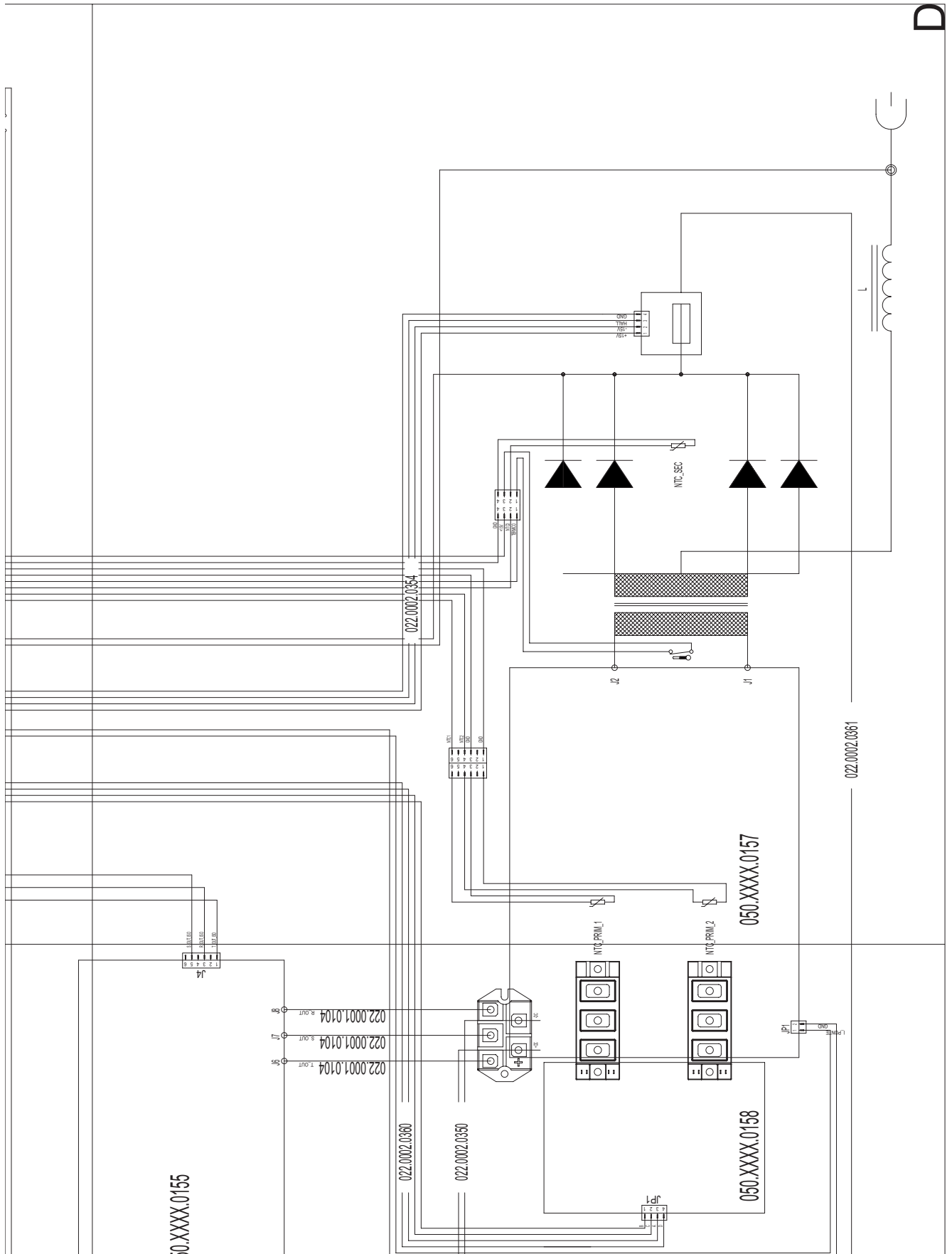

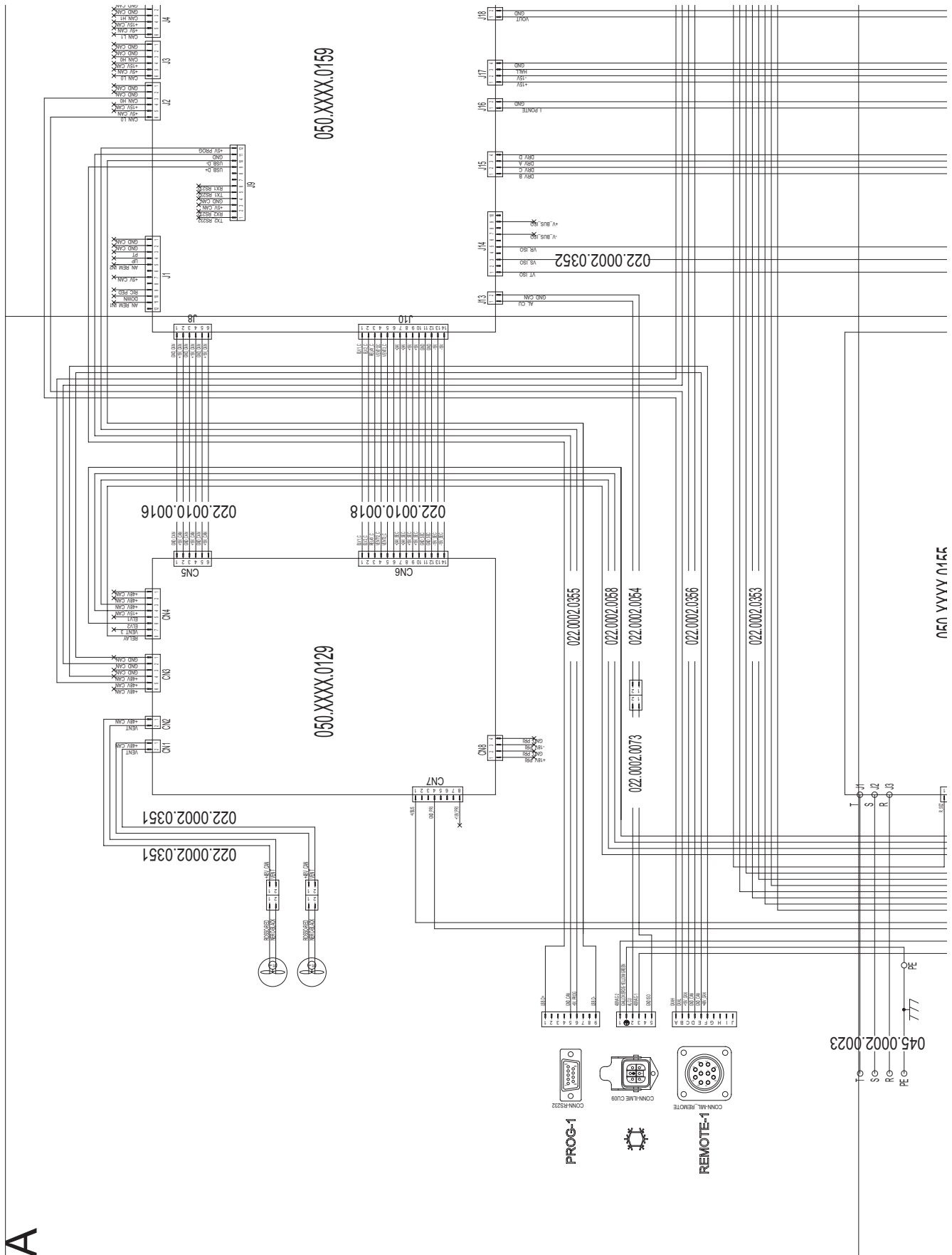

A

7 SPARE PARTS

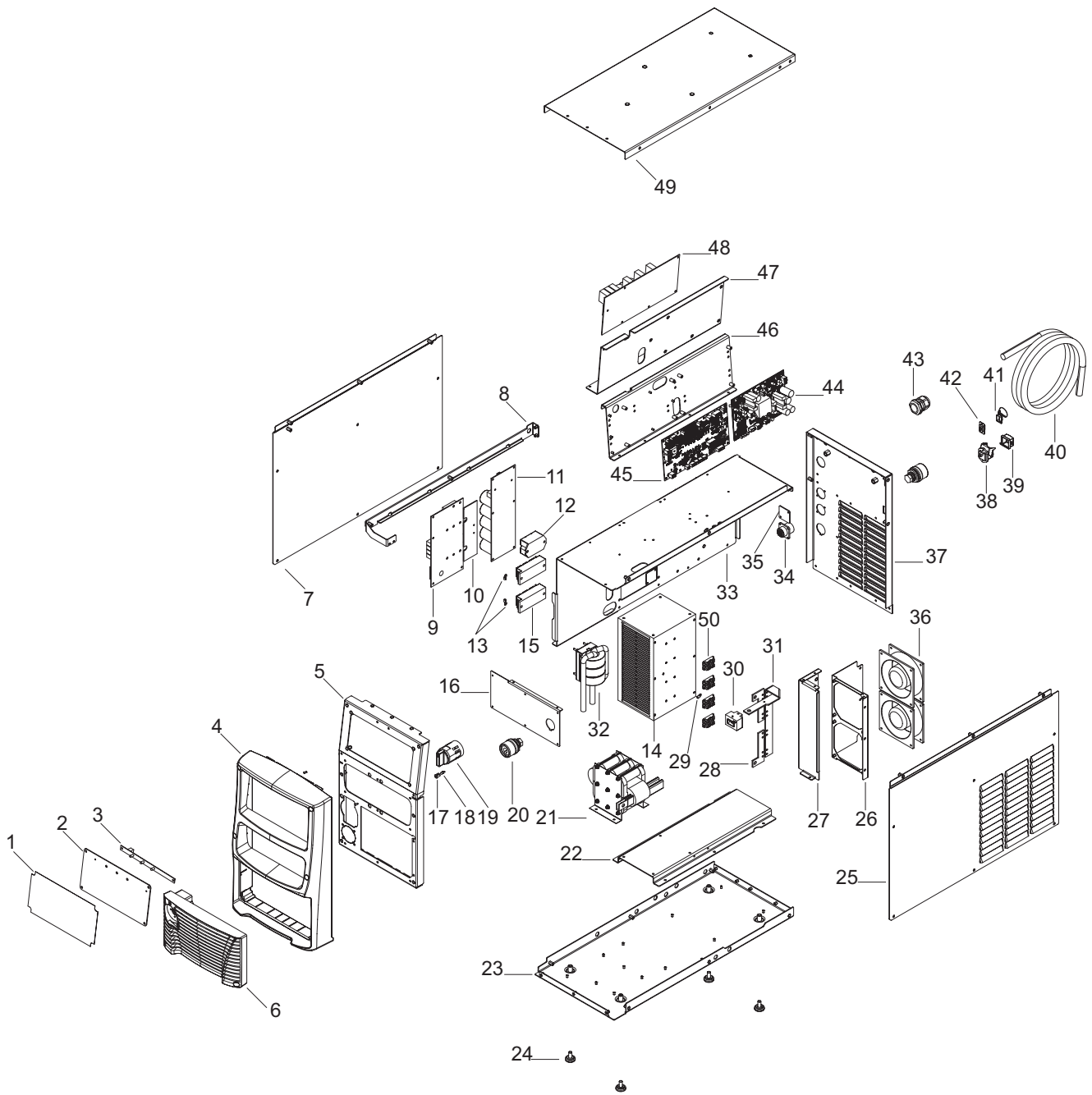

N°	CODE	DESCRIPTION
1	013.0021.1101	FRONT PANEL LABEL (403 MSR)
	013.0021.1001	FRONT PANEL LABEL (503 MSR)
2	016.4107.0001	FRONTAL PANEL PLATE
3	050.0002.0096	LED BOARD
4	012.0007.0010	FRONT PLASTIC
5	011.0013.0021	FRONT PLATE
6	012.0007.0020	PLASTIC LOUVRE
7	011.0000.1171	LEFT COVER
8	011.0013.0258	COVER PANEL SUPPORT PLATE
9	050.0001.0157	PRIMARY BOARD
10	050.0002.0158	DRIVER BOARD
11	050.0001.0156	ELECTROLYTIC CAPACITOR BOARD
12	032.0001.8216	THREE PHASE RECTIFIER BRIDGE
13	040.0003.1011	THERMAL CUT-OUT 2 NTC 10K
14	015.0001.0026	HEAT SINK
15	033.0006.0008	IGBT MODULE
16	011.0013.0259	FRONT SOCKETS PANEL
17	016.4107.0001	LED HOLDER
18	022.0002.0364	LED WIRING
19	040.0001.0016	THREE-POLE SWITCH
20	021.0001.0279	OUTPUT SOCKET
21	042.0003.0053	POWER TRANSFORMER
22	011.0013.0251	HEAT SINK SUPPORT PLATE
23	011.0013.0250	LOWER COVER
24	016.0009.0003	RUBBER FOOT
25	011.0000.1191	RIGHT COVER
26	011.0013.0254	INTERNAL FAN SUPPORT
27	011.0013.0253	SEPARATION PLATE
28	045.0006.0117	DIODES-TRANSFORMER COPPER BRACKET
29	040.0003.1008	THERMAL CUT-OUT NTC 10K
30	041.0004.0501	HALL EFFECT SENSOR
31	045.0006.0116	OUT COPPER BRACKET
32	044.0004.0029	OUTPUT INDUCTOR
33	011.0013.0252	UPPER PLATE
34	022.0002.0356	10 PIN CONNECTOR CABLE
35	011.0013.0222	COVER PLATE
36	003.0002.0017	FAN
37	011.0013.0255	FRONT PLATE
38	022.0002.0073	CU SUPPLY CABLE
39	021.0013.0007	ILME CONNECTOR CAP
40	045.0002.0023	SUPPLY CABLE
41	021.0014.0303	RS-232 CONNECTOR CAP
42	022.0002.0355	RS-232 WIRING
43	045.0000.0017	CABLE CLAMP

N°	CODE	DESCRIPTION
44	050.0004.0129	SUPPLIES BOARD
45	050.0001.0159	CONTROL BOARD (403MSR)
	050.0002.0159	CONTROL BOARD (503MSR)
46	011.0013.0257	RIGHT SUPPORT BOARD PLATE
47	011.0013.0256	LEFT SUPPORT BOARD PLATE
48	050.0001.0155	MAINS FILTER BOARD
49	011.0013.0260	UPPER COVER
50	032.0002.2003	ISOTOP DIODE





WELD THE WORLD